

**Secondary Two Mathematics:
An Integrated Approach
Module 8
Circles and Other Conics**

By

The Mathematics Vision Project:

Scott Hendrickson, Joleigh Honey,
Barbara Kuehl, Travis Lemon, Janet Sutorius
www.mathematicsvisionproject.org

**In partnership with the
Utah State Office of Education**

© 2013 Mathematics Vision Project | MVP

In partnership with the Utah State Office of Education

Licensed under the Creative Commons Attribution-NonCommercial-ShareAlike 3.0 Unported license.



Module 8 – Circles and Other Conics

Classroom Task: 8.1 Circling Triangles (or Triangulating Circles) – A Develop Understanding Task
Deriving the equation of a circle using the Pythagorean Theorem (G.GPE.1)

Ready, Set, Go Homework: Circles and Other Conics 8.1

Classroom Task: 8.2 Getting Centered – A Solidify Understanding Task
Complete the square to find the center and radius of a circle given by an equation (G.GPE.1)

Ready, Set, Go Homework: Circles and Other Conics 8.2

Classroom Task: 8.3 Circle Challenges – A Practice Understanding Task
Writing the equation of a circle given various information (G.GPE.1)

Ready, Set, Go Homework: Circles and Other Conics 8.3

Classroom Task: 8.4 Directing Our Focus– A Develop Understanding Task
Derive the equation of a parabola given a focus and directrix (G.GPE.2)

Ready, Set, Go Homework: Circles and Other Conics 8.4

Classroom Task: 8.5 Functioning with Parabolas – A Solidify Understanding Task
Connecting the equations of parabolas to prior work with quadratic functions (G.GPE.2)

Ready, Set, Go Homework: Circles and Other Conics 8.5

Classroom Task: 8.6 Turn It Around – A Solidify Understanding Task
Writing the equation of a parabola with a vertical directrix, and constructing an argument that all parabolas are similar (G.GPE.2)

Ready, Set, Go Homework: Circles and Other Conics 8.6

Classroom Task: 8.7H Operating on a Shoestring – A Solidify Understanding Task
To build understanding of the definition of a parabola as the set of all points equidistant from a given point (the focus) and a line (the directrix). (G.GPE, G.GPE.2)

Ready, Set, Go Homework: Circles and Other Conics 8.7H

Classroom Task: 8.8H What Happens if ... ? – A Solidify Understanding Task
To develop the definition of a hyperbola as the set of all points in a plane such that the difference between the distances from the point to each of the two foci is constant. (G.GPE, G.GPE.3)

Ready, Set, Go Homework: Circles and Other Conics 8.8H



8.1 Circling Triangles (or Triangulating Circles)

A Develop Understanding Task



© 2013 <http://flic.kr/p/5mEpJm>

Using the corner of a piece of colored paper and a ruler, cut a right triangle with a 6" hypotenuse, like so:

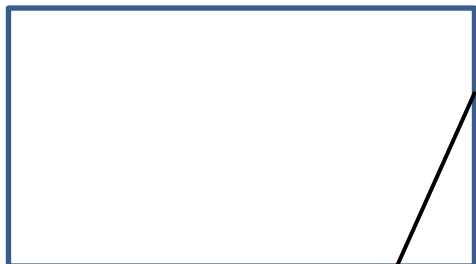

Use this triangle as a pattern to cut three more just like it, so that you have a total of four congruent triangles.

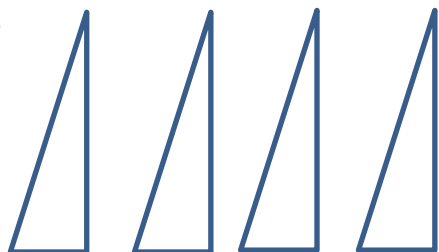

1. Choose one of the legs of the first triangle and label it x and label the other leg y . What is the relationship between the three sides of the triangle?
2. When you are told to do so, take your triangles up to the board and place each of them on the coordinate axis like this:

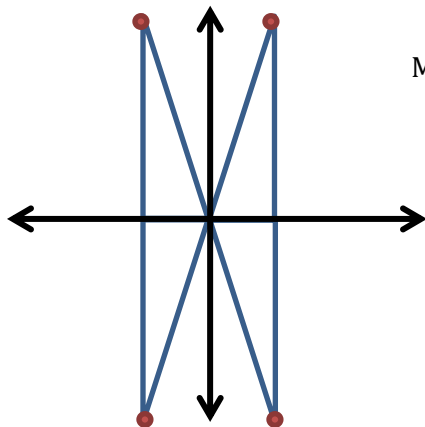

Mark the point at the end of each hypotenuse with a pin.



3. What shape is formed by the pins after the class has posted all of their triangles? Why would this construction create this shape?

4. What are the coordinates of the pin that you placed in:
 - a. the first quadrant?
 - b. the second quadrant?
 - c. the third quadrant?
 - d. the fourth quadrant?

5. Now that the triangles have been placed on the coordinate plane, some of your triangles have sides that are of length $-x$ or $-y$. Is the relationship $x^2 + y^2 = 6^2$ still true for these triangles? Why or why not?

6. What would be the equation of the graph that is the set on all points that are 6" away from the origin?

7. Is the point $(0, -6)$ on the graph? How about the point $(3, 5.193)$? How can you tell?

8. If the graph is translated 3 units to the right and 2 units up, what would be the equation of the new graph? Explain how you found the equation.



8.1 Circling Triangles (or Triangulating Circles) – Teacher Notes

A Develop Understanding Task

Purpose: This purpose of this task is for students to connect their geometric understanding of circles as the set of all point equidistant from a center to the equation of a circle. In the task, students construct a circle using right triangles with a radius of 6 inches. This construction is intended to focus students on the Pythagorean Theorem and to use it to generate the equation of a circle centered at the origin. After constructing a circle at the origin, students are asked to use their knowledge of translations to consider how the equation would change if the center of the circle is translated.

Core Standards Focus:

G.GPE Expressing Geometric Properties with Equations

Translate between the geometric description and the equation for a conic section

G.GPE.1 Derive the equation of a circle of given center and radius using the Pythagorean Theorem; complete the square to find the center and radius of a circle given by an equation.

Launch (Whole Class):

Be prepared for the class activity by having at least two sheets of colored paper (heavy paper is better), rulers and scissors for students to use. On a board in the classroom, create the coordinate axes with strings or tape. Prepare a way for students to mark the endpoint of their triangles with a tack or some other visible mark so that the circle that will be constructed is visible. Depending on the size of your class, you may choose to have several axes set up and divide students into groups.

Ask students to follow the instructions on the first page and post their triangles. Encourage some students to select the longest leg of the triangle to be x and others to select the shortest leg to be x so that there are as many different points on the circle formed as possible. Watch as students post their triangles to see that they get all four of them into the proper positions. An example of what the board will look like when the triangles are posted is:



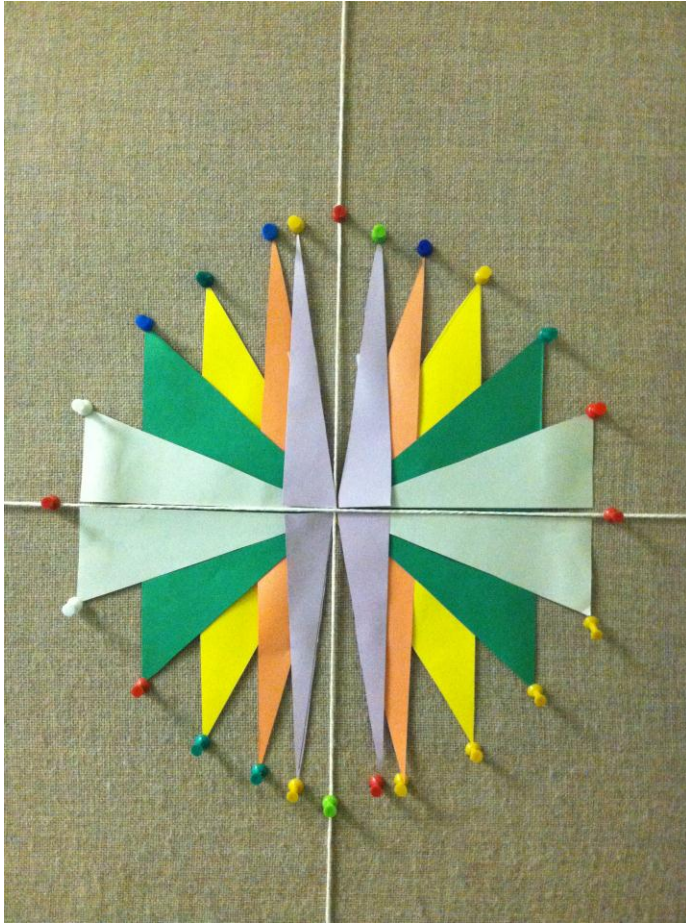

Tell students to work on problem #3 as other students finish posting their triangles. When all students are finished, ask students why the shape formed is a circle. They should be able to relate the idea that since each triangle had a hypotenuse of 6", they formed a circle that has a radius of 6". Use a 6" string to demonstrate how the radius sweeps around the circle, touching the endpoint of each hypotenuse.

Explore (Small Group): Ask students to work on the remaining questions. Monitor student work to support their thinking about the Pythagorean Theorem using x and y as the lengths of the legs of any of the right triangles used to form the circle. Question #5 may bring about confusion about the difference between $(-x)^2$ and $-x^2$. Remind students that in this case, x is a positive number, so $-x$ is a negative number, and the square of a negative number is positive.

Discuss (Whole Class): Begin the discussion with #6. Ask students for their equation and how their equation represents all the points on the circle. Press for students to explain how the equation works for points that lie in quadrants II, III, and IV.

© 2013 Mathematics Vision Project | MVP

In partnership with the Utah State Office of Education

Licensed under the Creative Commons Attribution-NonCommercial-ShareAlike 3.0 Unported license



Turn the discussion to #7. Ask how they decided if the points were on the circle. Some students may have tried measuring or estimating, so be sure that the use of the equation is demonstrated. After discussing the point $(3, 5.193)$, ask students what could be said about $(3, -5.193)$ or $(-3, -5.193)$ to highlight the symmetries and how they come up in the equation.

Finally, discuss the last question. Students should have various explanations for the change in the equation. Some may use the patterns they have observed in shifting functions, although it should be noted that this graph is not a function. Other students may be able to articulate the idea that $x-3$ represents the length of the horizontal side of the triangle that was originally length x , now that it has been moved three units to the right.

Aligned Ready, Set, Go: *Circles and Other Conics 8.1*



Name:

Circles and Other Conics | 8.1

Ready, Set, Go!

© 2013 <http://flic.kr/p/5mEpjm>

Ready

Topic: Special products and factors

Factor the following as the difference of 2 squares or as a perfect square trinomial. Do not factor if they are neither.

1. $25b^2 - 49y^2$

2. $100b^2 - 20b + 1$

3. $36b^2 + 30b + 25$

4. $x^2 + 6x - 9 - y^2$

5. $x^2 - 2xy + y^2 - 25$

6. $a^2 + 2ab + b^2 + 4a + 4b + 4$

7. $x^2 + 2xy + 12x + y^2 + 12y + 36$

8. $x^2 + 2cs + 2dx + c^2 + 2cd + d^2$

9. $144x^2 - 312xy + 169y^2$

Set

Topic: Writing the equations of circles.

Write the equation of each circle centered at the origin.

10.

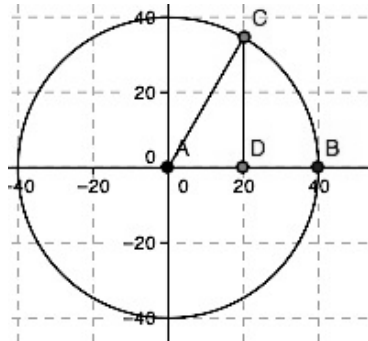

11.

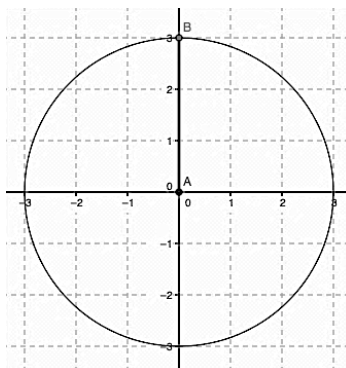

12.

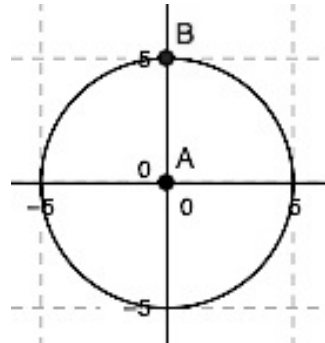

13.

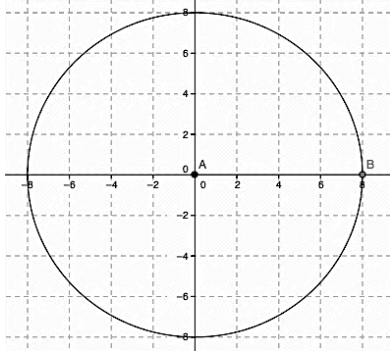

14.

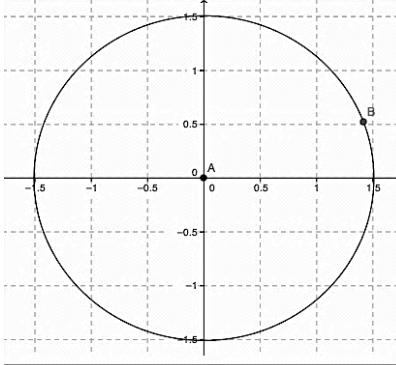

15.

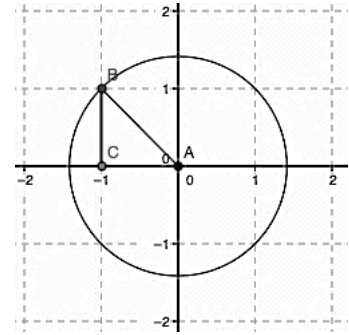
**Go**

Topic: Verifying Pythagorean triples.

Identify which sets of numbers could be the sides of a right triangle. Show your work.

16. $\{9, 12, 15\}$

17. $\{9, 10, \sqrt{19}\}$

18. $\{1, \sqrt{3}, 2\}$

19. $\{2, 4, 6\}$

20. $\{\sqrt{3}, 4, 5\}$

21. $\{10, 24, 26\}$

22. $\{\sqrt{2}, \sqrt{7}, 3\}$

23. $\{2\sqrt{2}, 5\sqrt{3}, 9\}$

24. $\{4ab^3\sqrt{10}, 6ab^3, 14ab^3\}$



8.2 Getting Centered

A Solidify Understanding Task

Malik's family has decided to put in a new sprinkling system in their yard. Malik has volunteered to lay the system out. Sprinklers are available at the hardware store in the following sizes:

- Full circle, maximum 15' radius
- Half circle, maximum 15' radius
- Quarter circle, maximum 15' radius



www.flickr.com/photos/paynomind/148476571

All of the sprinklers can be adjusted so that they spray a smaller radius. Malik needs to be sure that the entire yard gets watered, which he knows will require that some of the circular water patterns will overlap. He gets out a piece of graph paper and begins with a scale diagram of the yard. In this diagram, the length of the side of each square represents 5 feet.

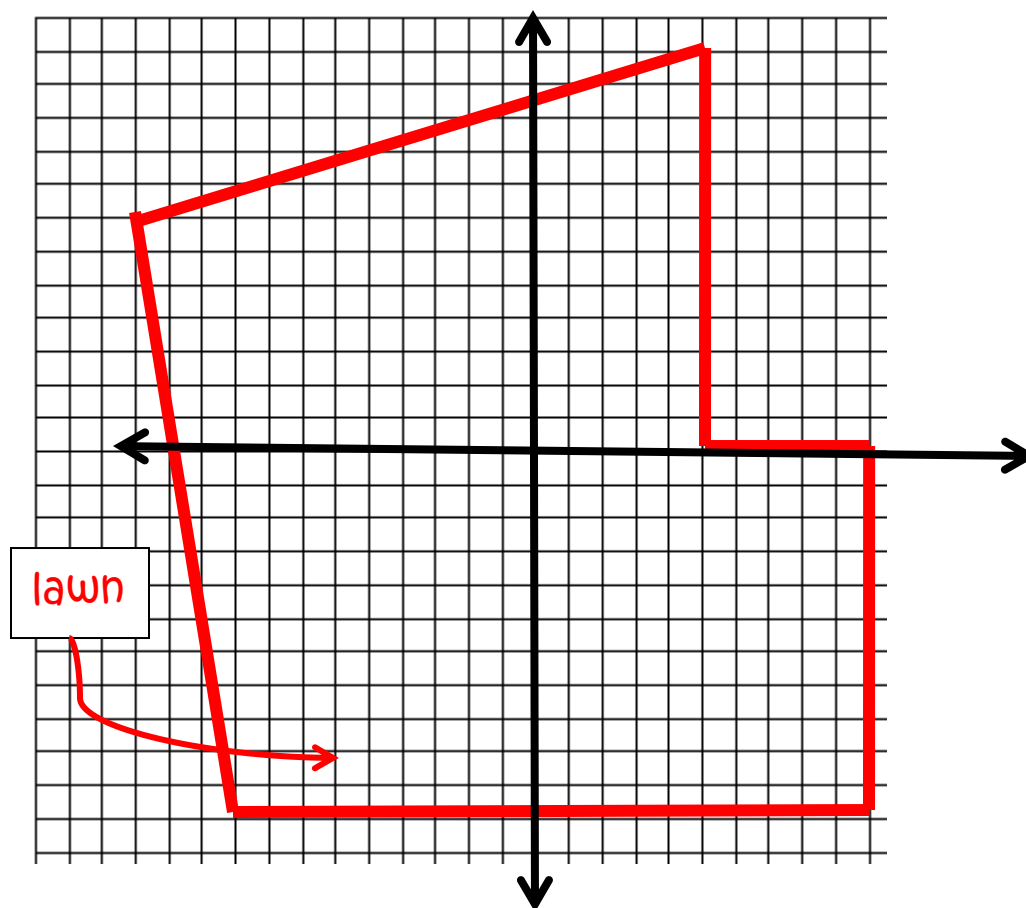

1. As he begins to think about locating sprinklers on the lawn, his parents tell him to try to cover the whole lawn with the fewest number of sprinklers possible so that they can save some money. The equation of the first circle that Malik draws to represent the area watered by the sprinkler is:

$$(x + 25)^2 + (y + 20)^2 = 225$$

Draw this circle on the diagram using a compass.

2. Lay out a possible configuration for the sprinkling system that includes the first sprinkler pattern that you drew in #1.
3. Find the equation of each of the full circles that you have drawn.

Malik wrote the equation of one of the circles and just because he likes messing with the algebra, he did this:

Original equation: $(x - 3)^2 + (y + 2)^2 = 225$

$$x^2 - 6x + 9 + y^2 + 4y + 4 = 225$$

$$x^2 + y^2 - 6x + 4y - 212 = 0$$

Malik thought, "That's pretty cool. It's like a different form of the equation. I guess that there could be different forms of the equation of a circle like there are different forms of the equation of a parabola or the equation of a line." He showed his equation to his sister, Sapana, and she thought he was nuts. Sapana, said, "That's a crazy equation. I can't even tell where the center is or the length of the radius anymore." Malik said, "Now it's like a puzzle for you. I'll give you an equation in the new form. I'll bet you can't figure out where the center is."



Sapana said, "Of course, I can. I'll just do the same thing you did, but work backwards."

4. Malik gave Sapana this equation of a circle:

$$x^2 + y^2 - 4x + 10y + 20 = 0$$

Help Sapana find the center and the length of the radius of the circle.

5. Sapana said, "Ok. I made one for you. What's the center and length of the radius for this circle?"

$$x^2 + y^2 + 6x - 14y - 42 = 0$$

6. Sapana said, "I still don't know why this form of the equation might be useful. When we had different forms for other equations like lines and parabolas, each of the various forms highlighted different features of the relationship." Why might this form of the equation of a circle be useful?

$$x^2 + y^2 + Ax + By + C = 0$$



Getting Centered – Teacher Notes

A Solidify Understanding Task

Purpose: The purpose of this task is to solidify understanding of the equation of the circle. The task begins with sketching circles and writing their equations. It proceeds with the idea of squaring the $(x - h)^2$ and $(y - k)^2$ expressions to obtain a new form of an equations. Students are then challenged to reverse the process to find the center of the circle.

Core Standards Focus:

G.GPE Expressing Geometric Properties with Equations

Translate between the geometric description and the equation for a conic section

G.GPE.1 Derive the equation of a circle of given center and radius using the Pythagorean Theorem; complete the square to find the center and radius of a circle given by an equation.

Launch (Whole Class): Begin the task by helping students to understand the context of developing a diagram for a sprinkling system. The task begins with students drawing circles to cover the yard and writing equations for the circles that they have sketched. Allow students some time to work to make their diagrams and write their equations. As students are working, be sure that they are accounting for the scale as they name the center of their circles. Ask several students to share their equations. After several students have shared, ask one student to take the last equation shared and square the $(x - h)^2$ and $(y - k)^2$ expressions and simplify the remaining equation. Tell students that this is what Malik did and now their job is to take the equation back to the form in which they can easily read the center and radius.

Explore (Small Group): Since students have previously completed the square for parabolas, some students will think to apply the same process here. Monitor their work, watching for groups that have different answers for the same equation (hopefully, one of them is correct).

Discuss (Whole Class): Begin the discussion by posting two different equations that answer question #4. Ask students how they can decide which equation is correct. They may suggest working backwards to the original equation, or possibly checking a point. Decide which equation is correct and ask that group to describe the process they used to get the answer. Ask another group that has a correct version of #5 to show how they obtained their answer. You may also wish to discuss #6. Wrap up the lesson up by working with the class to create a set of steps that they can follow to get the equation back to center/radius form.

Aligned Ready, Set, Go: *Circles and Other Conics 8.2*



Name: _____

Circles and Other Conics | 8.2

Ready, Set, Go!



©2013www.flickr.com/photos/paynomind/148476571

Ready

Topic: Making perfect square trinomials.

Fill in the number that completes the square. Then write the trinomial in factored form.

1. $x^2 + 6x + \underline{\hspace{2cm}}$ 2. $x^2 - 14x + \underline{\hspace{2cm}}$

3. $x^2 - 50x + \underline{\hspace{2cm}}$ 4. $x^2 - 28x + \underline{\hspace{2cm}}$

On the next set of problems, leave the number that completes the square as a fraction. Then write the trinomial in factored form.

5. $x^2 - 11x + \underline{\hspace{2cm}}$ 6. $x^2 + 7x + \underline{\hspace{2cm}}$ 7. $x^2 + 15x + \underline{\hspace{2cm}}$

8. $x^2 + \frac{2}{3}x + \underline{\hspace{2cm}}$ 9. $x^2 - \frac{1}{5}x + \underline{\hspace{2cm}}$ 10. $x^2 - \frac{3}{4}x + \underline{\hspace{2cm}}$

Set

Topic: Writing equations of circles with center (h, k) and radius r .

Write the equation of the circle.

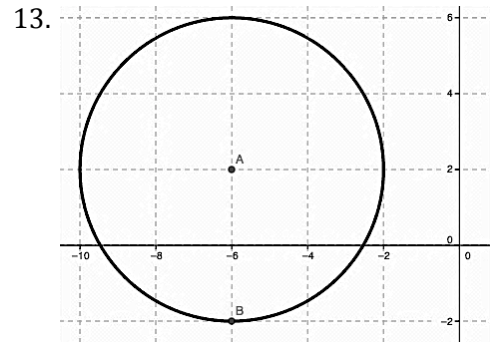
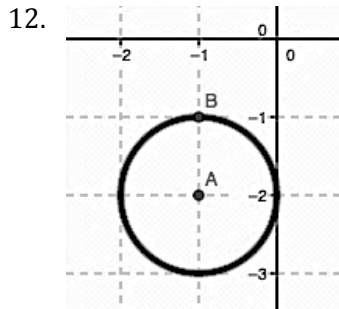
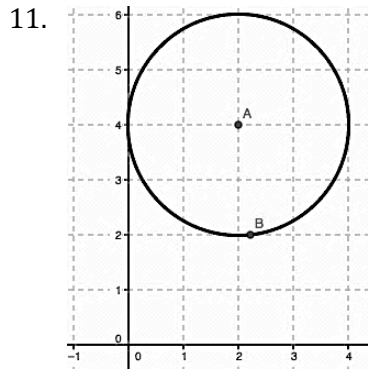

Write the equation of the circle with the given center and radius. Then write it in expanded form.

14. Center: $(5, 2)$, Radius: 13

15. Center: $(-6, -10)$, Radius: 9

16. Center: $(0, 8)$, Radius: 15

17. Center: $(19, -13)$, Radius: 1

18. Center: $(-1, 2)$, Radius: 10

19. Center: $(-3, -4)$, Radius: 8

Go

Topic: Verifying if a point is a solution.

Identify which point is a solution to the given equation. Show your work.

20. $y = \frac{4}{5}x - 2$

a. $(-15, -14)$

b. $(10, 10)$

21. $y = 3|x|$

a. $(-4, -12)$

b. $(-\sqrt{5}, 3\sqrt{5})$

22. $y = x^2 + 8$

a. $(\sqrt{7}, 15)$

b. $(\sqrt{7}, -1)$

23. $y = -4x^2 + 120$

a. $(5\sqrt{3}, -180)$

b. $(5\sqrt{3}, 40)$

24. $x^2 + y^2 = 9$

a. $(8, -1)$

b. $(-2, \sqrt{5})$

25. $4x^2 - y^2 = 16$

a. $(-3, \sqrt{10})$

b. $(-2\sqrt{2}, 4)$



8.3 Circle Challenges

A Practice Understanding Task

Once Malik and Sapana started challenging each other with circle equations, they got a little more creative with their ideas. See if you can work out the challenges that they gave each other to solve. Be sure to justify all of your answers.



www.flickr.com/photos/oschene

1. Malik's challenge:
What is the equation of the circle with center $(-13, -16)$ and containing the point $(-10, -16)$ on the circle?

2. Sapana's challenge:
The points $(0, 5)$ and $(0, -5)$ are the endpoints of the diameter of a circle. The point $(3, y)$ is on the circle. What is a value for y ?

3. Malik's challenge:
Find the equation of a circle with center in the first quadrant and is tangent to the lines $x = 8$, $y = 3$, and $x = 14$.

4. Sapana's challenge:
The points $(4, -1)$ and $(-6, 7)$ are the endpoints of the diameter of a circle. What is the equation of the circle?



5. Malik's challenge:
Is the point (5,1) inside, outside, or on the circle $x^2 - 6x + y^2 + 8y = 24$? How do you know?
6. Sapana's challenge:
The circle defined by $(x - 1)^2 + (y + 4)^2 = 16$ is translated 5 units to the left and 2 units down. Write the equation of the resulting circle.
7. Malik's challenge:
There are two circles, the first with center (3,3) and radius r_1 , and the second with center (3, 1) and radius r_2 .
- Find values r_1 and r_2 of so that the first circle is completely enclosed by the second circle.
 - Find one value of r_1 and one value of r_2 so that the two circles intersect at two points.
 - Find one value of r_1 and one value of r_2 so that the two circles intersect at exactly one point.



Circle Challenges – Teacher Notes

A Practice Understanding Task

Purpose:

The purpose of this task is for students to practice using the equation of the circle in different ways. In each case, they must draw inferences from the information given and use the information to find the equation of the circle or to justify conclusions about the circle. They will use the distance formula to find the measure of the radius and the midpoint formula to find the center of a circle.

Core Standards Focus:

G.GPE Expressing Geometric Properties with Equations

Translate between the geometric description and the equation for a conic section

G.GPE.1 Derive the equation of a circle of given center and radius using the Pythagorean Theorem; complete the square to find the center and radius of a circle given by an equation.

Launch (Whole Class):

Begin the task by telling students that they will be solving the circle challenges by using the information given, ideas that they have learned in the past (like the distance and midpoint formulas), and their logic to write equations and justify conclusions about circles. It will probably be useful to have graph paper available to sketch the circles based on the information given.

Explore (Small Group):

Monitor students as they work, focusing on how they are making sense of the problems and using the information. Encourage students to draw the situation and visualize the circle to help when they are stuck. Insist upon justification, asking, “How do you know?”

Discuss (Whole Class):

Select problems that were challenging for the class or highlighted important ideas or useful strategies. Problem #4 is recommended for this purpose, but it is also important to select the problems that have generated interest in the class.

Aligned Ready, Set, Go: *Circles and Other Conics 8.3*

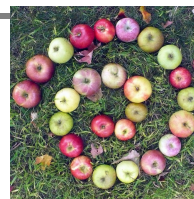

Ready, Set, Go!

©2013www.flickr.com/photos/loschene

Ready

Topic: Finding the distance between 2 points.

Use the distance formula $d = \sqrt{(x_2 - x_1)^2 + (y_2 - y_1)^2}$ to find the distance between the given points. Leave your answer in simplest radical form.

1. $A(18, -12)$ $B(10, 4)$
2. $G(-11, -9)$ $H(-3, 7)$
3. $J(14, -20)$ $K(5, 5)$
4. $M(1, 3)$ $P(-2, 7)$
5. $Q(8, 2)$ $R(3, 7)$
6. $S(-11, 2\sqrt{2})$ $T(-5, -4\sqrt{2})$
7. $W(-12, -2\sqrt{2})$ $Z(-7, -3\sqrt{2})$

Set

Topic: Writing equations of circles

Use the information provided to write the equation of the circle in standard form.

8. Center $(-16, -5)$ and the circumference is 22π
9. Center $(13, -27)$ and the area is 196π
10. Diameter measures 15 units and the center is at the intersection of $y = x + 7$ and $y = 2x - 5$
11. Lies in quadrant 2 Tangent to $x = -12$ and $x = -4$



12. Center $(-14, 9)$ Point on circle $(1, 11)$

13. Center lies on the y axis Tangent to $y = -2$ and $y = -17$

14. Three points on the circle are $(-8, 5), (3, -6), (14, 5)$

15. I know three points on the circle are $(-7, 6), (9, 6)$, and $(-4, 13)$. I think that the equation of the circle is $(x-1)^2 + (y-6)^2 = 64$. Is this the correct equation for the circle?

Convince me!

Go

Topic: Finding the value of "B" in a quadratic of the form $Ax^2 + Bx + C$ in order to create a perfect square trinomial.

Find the value of "B," that will make a perfect square trinomial. Then write the trinomial in factored form.

16. $x^2 + \underline{\hspace{2cm}}x + 36$

17. $x^2 + \underline{\hspace{2cm}}x + 100$

18. $x^2 + \underline{\hspace{2cm}}x + 225$

19. $9x^2 + \underline{\hspace{2cm}}x + 225$

20. $16x^2 + \underline{\hspace{2cm}}x + 169$

21. $x^2 + \underline{\hspace{2cm}}x + 5$

22. $x^2 + \underline{\hspace{2cm}}x + \frac{25}{4}$

23. $x^2 + \underline{\hspace{2cm}}x + \frac{9}{4}$

24. $x^2 + \underline{\hspace{2cm}}x + \frac{49}{4}$



8.4 Directing Our Focus

A Develop Understanding Task

On a board in your classroom, your teacher has set up a point and a line like this:



www.flickr.com/photos/pixelthing

● Focus (point A)

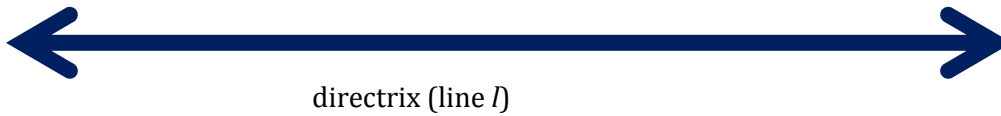

We're going to call the line a directrix and the point a focus. They've been labeled on the drawing.

Similar to the circles task, the class is going to construct a geometric figure using the focus (point A) and directrix (line l).

1. Cut two pieces of string with the same length.



2. Mark the midpoint of each piece of string with a marker.

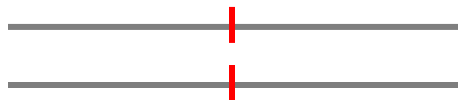

3. Position the string on the board so that the midpoint is equidistant from the focus (point A) and the directrix (line l), which means that it must be perpendicular to the directrix. While holding the string in this position, put a pin through the midpoint. Depending on the size of your string, it will look something like this:

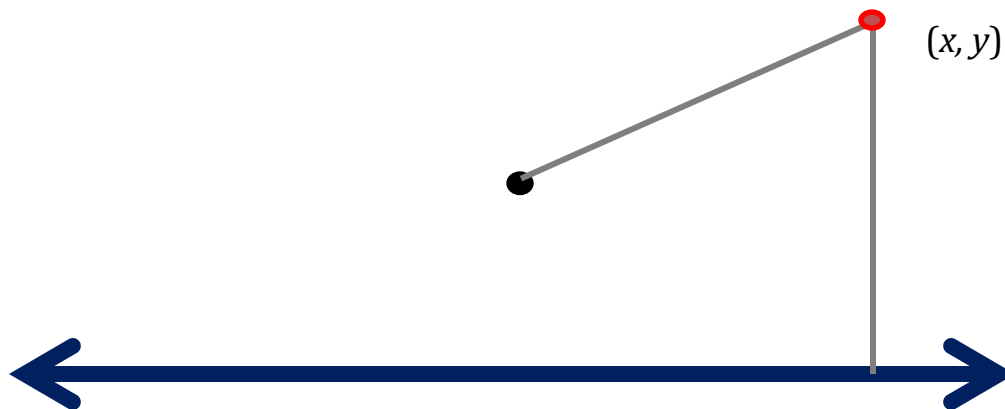

4. Using your second string, use the same procedure to post a pin on the other side of the focus.
5. As your classmates post their strings, what geometric figure do you predict will be made by the tacks (the collection of all points like (x, y) show in the figure above)? Why?
6. Where is the vertex of the figure located? How do you know?
7. Where is the line of symmetry located? How do you know?



8. Consider the following construction with focus point A and the x axis as the directrix. Use a ruler to complete the construction of the parabola in the same way that the class constructed the parabola with string.

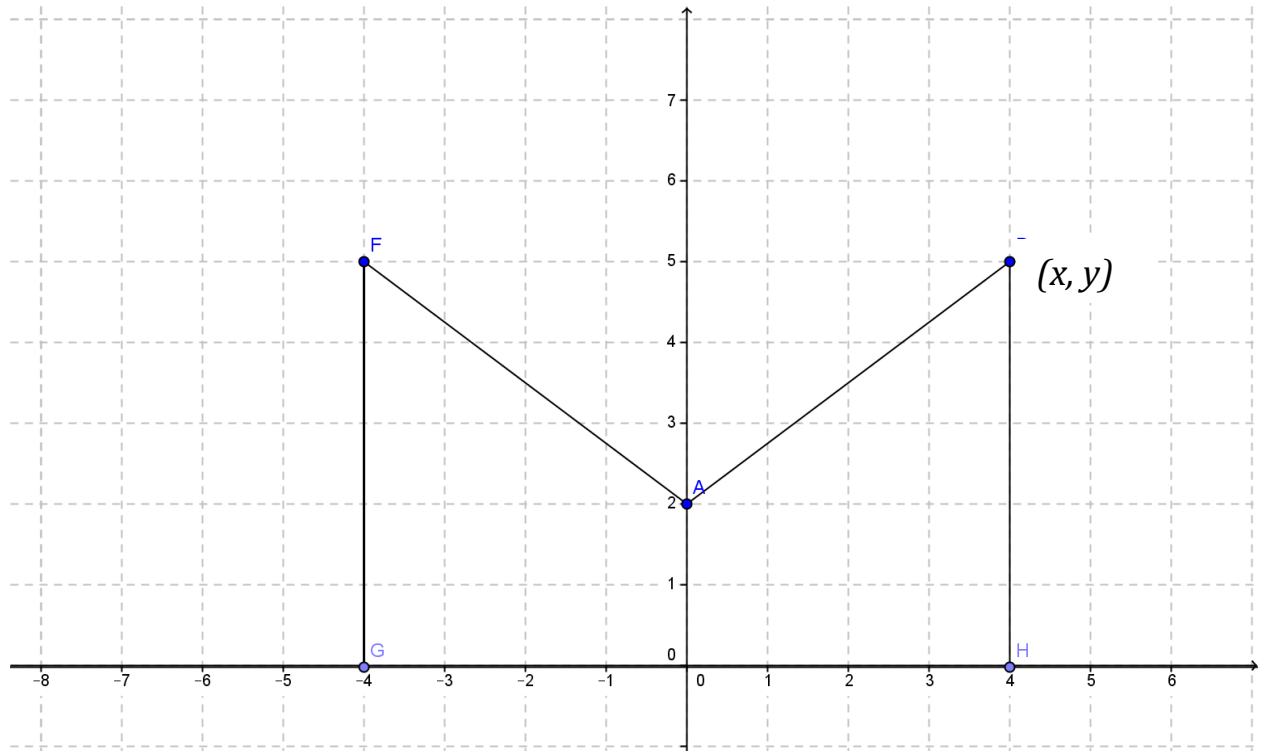

9. You have just constructed a parabola based upon the definition: A parabola is the set of all points (x, y) equidistant from a line l (the directrix) and a point not on the line (the focus). Use this definition to write the equation of the parabola above, using the point (x, y) to represent any point on the parabola.
10. How would the parabola change if the focus was moved up, away from the directrix?
11. How would the parabola change if the focus was moved down, toward the directrix?
12. How would the parabola change if the focus was moved down, below the directrix?



Directing Our Focus – Teacher Notes

A Develop Understanding Task

Note: Having a dynamic sketch of a parabola with a moveable focus and directrix available for the class discussion would be very helpful. One possibility is a free GeoGebra applet available at: <http://www.slu.edu/classes/maymk/GeoGebra/Parabola.html>.

Purpose:

The purpose of this task is to develop the definition of a parabola as the set of all points equidistant from a given point (the focus) and a line (the directrix). Only those parabolas with horizontal directrices are considered in this task. Students develop an equation for a parabola based on the definition, using the distance formula. Students are also asked to consider the relationship between the focus and directrix and how the parabola changes as they are moved in relation to each other.

Core Standards Focus:

G.GPE Expressing Geometric Properties with Equations

Translate between the geometric description and the equation for a conic section

G.GPE.2. Derive the equation of a parabola given a focus and directrix.

Note: Connect the equations of circles and parabolas to prior work with quadratic equations. The directrix should be parallel to a coordinate axis.

Vocabulary: focus, directrix

Launch (Whole Class):

Be prepared for the class activity by having scissors, markers, rulers, and string for students to use. Have a large cork board with focus and directrix set up for students to use, as pictured in the task.

Lead the class in following the directions for cutting and marking the strings and then posting them on the board. Before anyone posts a string, ask students what shape they think will be made and why. Watch as students post their strings to be sure that they are perpendicular to the directrix and pulled tight both directions so that they look like the illustration.

After students have identified that the figure formed is a parabola, have them work individually on completing the diagram in #8. When completed, ask how they find the vertex point on a parabola? Be sure that the discussion includes the fact that the vertex will be the point on the line of symmetry that is the midpoint between the focus and the directrix. How is the vertex like other points on the parabola? (It is equidistant from the focus and the directrix.) How is it different? (It's



the only point of the parabola on the line of symmetry.) Direct the discussion to the line of symmetry. Where is it on the parabola they just made? How could it be found on any parabola, given the focus and directrix?

After their work on #8, explain the geometric definition of a parabola given in #9. Then have students work together to use the definition to write the equation of the parabola.

Explore (Small Group):

Monitor students as they work to be sure that they are using the point marked (x, y) to represent any point on the parabola, rather than naming it $(4,5)$. If they have written the equation using $(4,5)$ then ask them how they would change their initial equation to call the point (x, y) instead. After they have written their equation they may want to test it with the point $(4, 5)$ since they know it is on the parabola. If students need help getting started, help them to focus on the distance between the (x, y) and the focus $(0,2)$ and (x, y) and the directrix, $y = 0$. Ask how they could represent those distances algebraically.

Be sure that students have time to share their ideas about problems 10 -12 so that the class discussion of the relationship of the focus and the directrix is robust.

Discuss (Whole Class):

When students have finished their work on the equation, ask a group to present and explain their work. A possible version is below:

Distance from (x, y) to focus $(0, 2)$ = distance from (x, y) to x-axis

$$\begin{aligned}\sqrt{(x - 0)^2 + (y - 2)^2} &= y \\(x - 0)^2 + (y - 2)^2 &= y^2 && \text{Squaring both sides} \\x^2 + y^2 - 4y + 4 &= y^2 && \text{Simplifying} \\x^2 - 4y + 4 &= 0 && \text{Simplifying} \\x^2 + 4 &= 4y && \text{Solving for y} \\\frac{x^2}{4} + 1 &= y && \text{Solving for y}\end{aligned}$$

Ask students how this equation matches what they already know about the parabola they have drawn. Where is the vertex in the equation? How could they use the equation to predict how wide or narrow the parabola will be?



Turn the discussion to questions 10 -12. Ask various students to explain their answers. Use the parabola applet to test their conjectures about the effect of moving the focus in relation to the directrix.

Aligned Ready, Set, Go: *Circles and Other Conics 8.4*



Name: _____

Circles and Other Conics | 8.4

©2013 www.flickr.com/photos/pixelthing

Ready, Set, Go!

Ready

Topic: Graphing quadratics

Graph each set of functions on the same coordinate axes. Describe in what way the graphs are the same and in what way they are different.

1. $y = x^2, y = 2x^2, y = 4x^2$

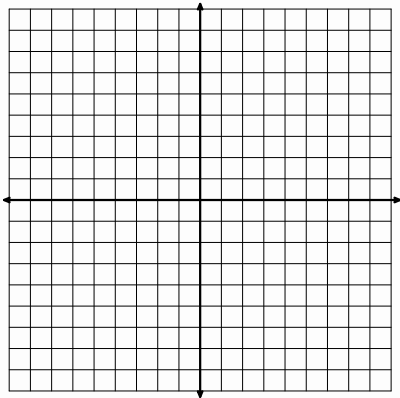

2. $y = \frac{1}{4}x^2, y = -x^2, y = -4x^2$

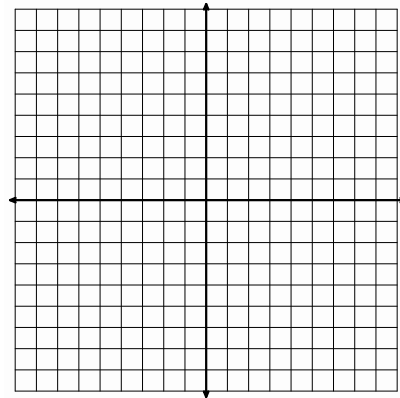

3. $y = \frac{1}{4}x^2, y = x^2 - 2, y = \frac{1}{4}x^2 - 2, y = 4x^2 - 2$

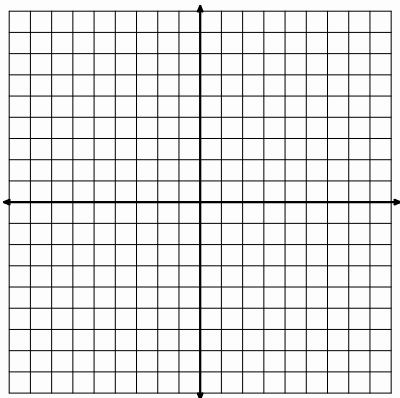

4. $y = x^2, y = -x^2, y = x^2 + 2, y = -x^2 + 2$

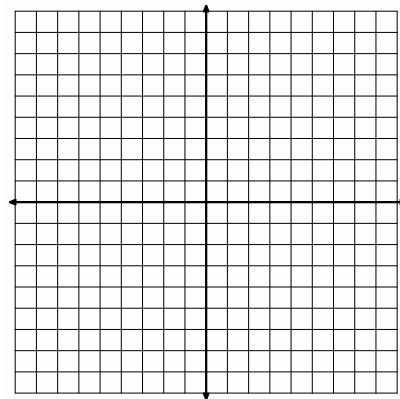

Set Topic: Sketching a parabola using the conic definition.

Use the conic definition of a parabola to sketch a parabola defined by the given focus F and the equation of the directrix.

Begin by graphing the focus, the directrix, and point P_1 . Use the distance formula to find FP_1 and find the vertical distance between P_1 and the directrix by identifying point H on the directrix and counting the distance. Locate the point P_2 , (the point on the parabola that is a reflection of P_1 across the axis of symmetry.) Locate the vertex V . Since the vertex is a point on the parabola, it must lie equidistant between the focus and the directrix. Sketch the parabola. Hint: the parabola always “hugs” the focus.

Example: $F(4,3)$, $P_1(8,6)$, $y=1$

$$FP_1 = \sqrt{(4-8)^2 + (3-6)^2} = \sqrt{16+9} = \sqrt{25} = 5$$

$$P_1H = 5$$

P_2 is located at $(0,6)$

V is located at $(4,2)$

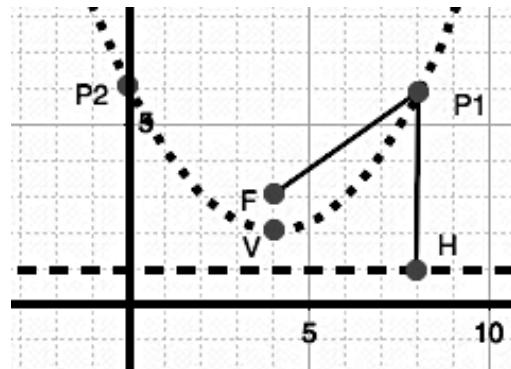

5. $F(1,-1)$, $P_1(3,-1)$ $y=-3$

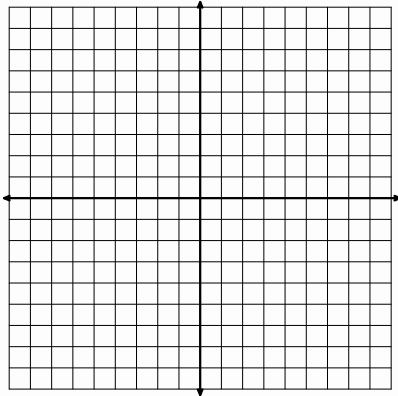

6. $F(-5,3)$, $P_1(-1,3)$ $y=7$

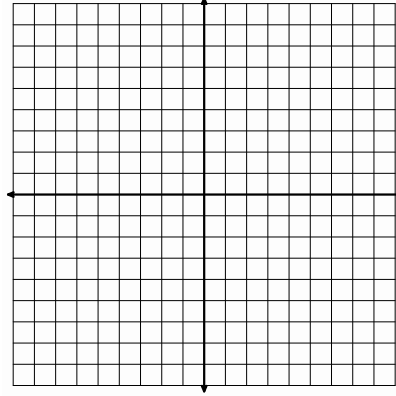

7. $F(2,1)$, $P_1(-6,7)$ $y=-3$

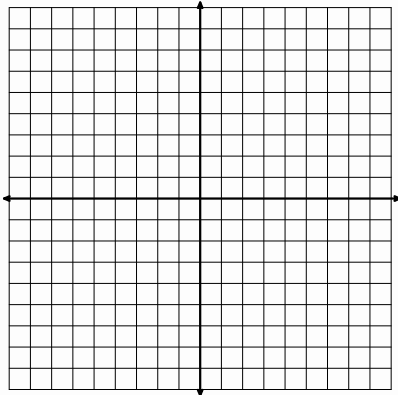

8. $F(1,-1)$, $P_1(-9,-1)$ $y=9$

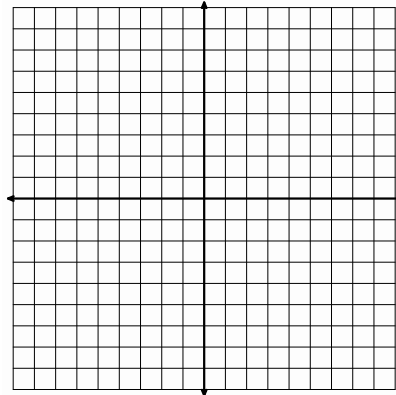

Circles and Other Conics | 8.4

9. Find a square piece of paper (a post-it note will work). Fold the square in half vertically and put a dot anywhere on the fold. Let the edge of the paper be the directrix and the dot be the focus. Fold the edge of the paper (the directrix) up to the dot repeatedly from different points along the edge. The fold lines between the focus and the edge should make a parabola.

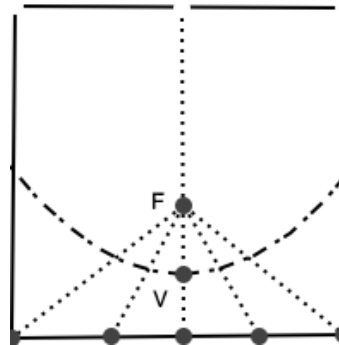

Experiment with a new paper and move the focus.
Use your experiments to answer the following questions.

10. How would the parabola change if the focus were moved up, away from the directrix?
11. How would the parabola change if the focus were moved down, toward the directrix?
12. How would the parabola change if the focus were moved down, below the directrix?

Go

Topic: Finding the center and radius of a circle.

Write each equation in standard form. Find the center (h, k) and radius r of the circle.

13. $x^2 + y^2 + 4y - 12 = 0$

14. $x^2 + y^2 - 6x - 3 = 0$

15. $x^2 + y^2 + 8x + 4y - 5 = 0$

16. $x^2 + y^2 - 6x - 10y - 2 = 0$

17. $x^2 + y^2 - 6y - 7 = 0$

18. $x^2 + y^2 - 4x + 8y + 6 = 0$

19. $x^2 + y^2 - 4x + 6y - 72 = 0$

20. $x^2 + y^2 + 12x + 6y - 59 = 0$

21. $x^2 + y^2 - 2x + 10y + 21 = 0$

22. $4x^2 + 4y^2 + 4x - 4y - 1 = 0$

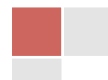

8.5 Functioning With Parabolas

A Solidify Understanding Task

Sketch the graph (accurately), find the vertex and use the geometric definition of a parabola to find the equation of these parabolas.



1. Directrix $y = -4$, Focus $A(2, -2)$

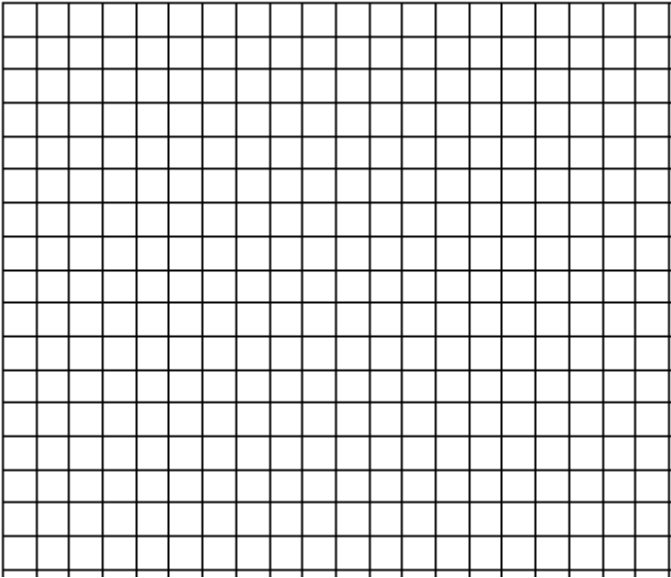

Vertex _____

Equation:

2. Directrix $y = 2$, Focus $A(-1, 0)$

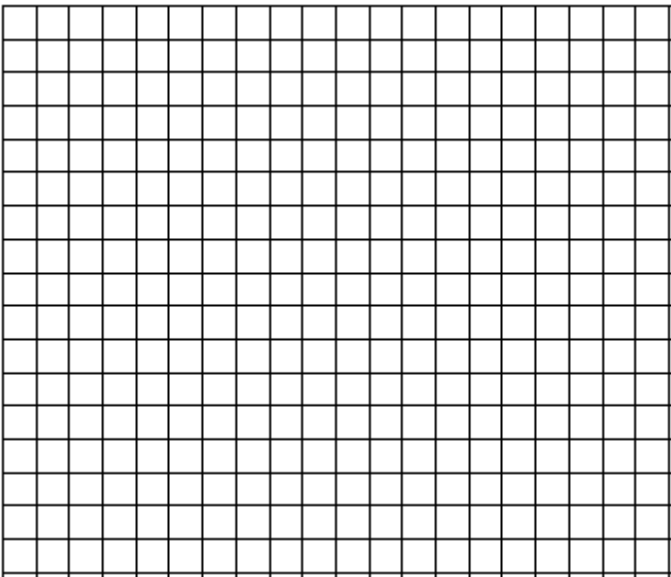

Vertex _____

Equation:



3. Directrix $y = 3$, Focus $A(1, 7)$

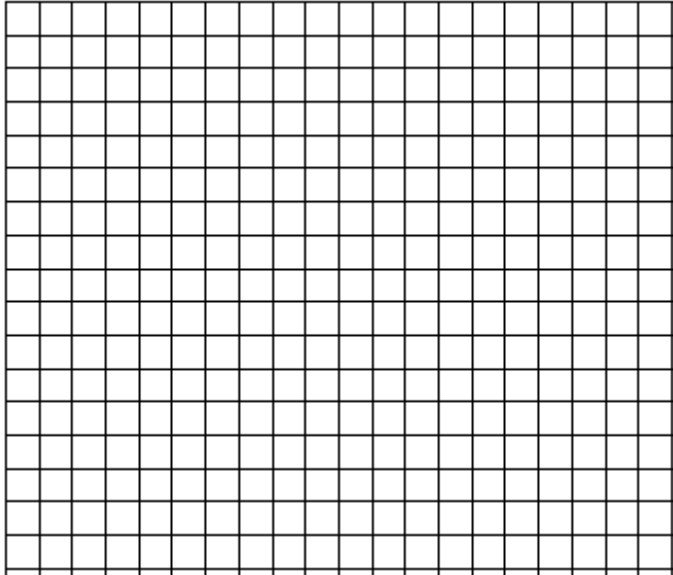

Vertex _____

Equation:

4. Directrix $y = 3$, Focus $A(2, -1)$

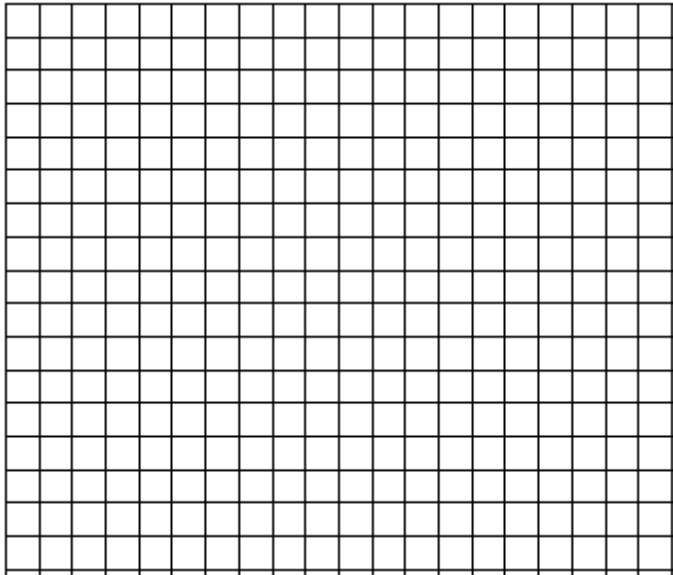

Vertex _____

Equation:

5. Given the focus and directrix, how can you find the vertex of the parabola?



6. Given the focus and directrix, how can you tell if the parabola opens up or down?

7. How do you see the distance between the focus and the vertex (or the vertex and the directrix) showing up in the equations that you have written?

8. Describe a pattern for writing the equation of a parabola given the focus and directrix.

9. Annika wonders why we are suddenly thinking about parabolas in a completely different way than when we did quadratic functions. She wonders how these different ways of thinking match up. For instance, when we talked about quadratic functions earlier we started with $y = x^2$. “Hmmm. I wonder where the focus and directrix would be on this function,” she thought. Help Annika find the focus and directrix for $y = x^2$.



10. Annika thinks, “Ok, I can see that you can find the focus and directrix for a quadratic function, but what about these new parabolas. Are they quadratic functions? When we work with families of functions, they are defined by their rates of change. For instance, we can tell a linear function because it has a constant rate of change.” How would you answer Annika? Are these new parabolas quadratic functions? Justify your answer using several representations and the parabolas in problems 1-4 as examples.



Functioning with Parabolas – Teacher Notes

A Solidify Understanding Task

Purpose: The purpose of this task is to solidify students’ understanding of the geometric definition of a parabola and to connect it to their previous experiences with quadratic functions. The task begins with students writing equations for specific parabolas with specific relationships between the focus and directrix. Students use this experience to generalize a strategy for writing the equation of a parabola, solidifying how to find the vertex and to use the distance between the focus and the vertex (or the distance between the vertex and the directrix) in writing an equation. Students are then asked to find the focus and directrix for $y = x^2$ to illustrate that the focus and directrix could be identified for the parabolas that they worked with as the graphs of quadratic functions. Finally, they are asked to verify that parabolas constructed with a horizontal directrix from a geometric perspective will also be quadratic functions, based upon a linear rate of change.

G.GPE Expressing Geometric Properties with Equations

Translate between the geometric description and the equation for a conic section

G.GPE.2. Derive the equation of a parabola given a focus and directrix.

Note: Connect the equations of circles and parabolas to prior work with quadratic equations. The directrix should be parallel to a coordinate axis.

NOTE: Rulers should be available for the task.

Launch (Whole Class): Begin by having students individually work the first problem. Have one student that has done a good job of accurately sketching the parabola demonstrate for the class. The first problems are very similar to the work done in “Directing Our Focus”, but each problem has been selected so that students will see different distances between the focus and the directrix and use them to draw conclusions later in the task. After the first problem is done as a class, the rest of the task can be done in small groups.

Explore (Small Group): As students are working on the task, listen to see what they are noticing about finding the vertex. They should identify that the vertex is on the line of symmetry, which is perpendicular to the directrix, and that the vertex is the midpoint between the focus and directrix. They should also be noticing how it shows up in the equation, particularly that it is easier to recognize if the $(x-h)^2$ term in the equation is not expanded. They should also notice the distance from the vertex to the focus, a , and where that is occurring in the equation. Identify students for the discussion that can describe the patterns that they see with the parabola and the equation and have developed a good “recipe” for writing an equation.



As you monitor student work on #10, identify student use of tables, equations, and graphs to demonstrate that the parabolas they are working with fit into the quadratic family of functions because they have linear rates of change.

Discuss (Whole Class): Begin the discussion with question #8. Ask a couple of groups that have developed an efficient strategy for writing the equation of a parabola given the focus and directrix to present their work. (Students will be asked to generate a general form of the equation in the RSG). Ask the class to compare and edit the strategies so that they have a method that they are comfortable with using for this purpose. Then ask them to use the process in reverse and tell how they found the focus and directrix for $y = x^2$ (question 9).

Move the discussion to #10. Ask various students to show how the parabolas are quadratic functions using tables, graphs, and equations. Focus on how the linear rate of change shows up in each representation. Connect the equations and graphs to the transformation perspective that they worked with in previous modules.

Aligned Ready, Set, Go: *Circles and Other Conics 8.5*

If you are looking for student project on parabolas in real life, check out:

<https://xsquared.wikispaces.com/Chapter12Project>



Name: _____

Circles and Other Conics | 8.5

Ready, Set, Go!



©2013www.flickr.com/photos/morethanmaths/226219461

Ready

Topic: Standard form of a quadratic.

Verify that the given point lies on the graph of the parabola described by the equation.
(Show your work.)

1. $(6,0)$ $y = 2x^2 - 9x - 18$

2. $(-2,49)$ $y = 25x^2 + 30x + 9$

3. $(5,53)$ $y = 3x^2 - 4x - 2$

4. $(8,2)$ $y = \frac{1}{4}x^2 - x - 6$

Set

Topic: the equation of a parabola based on the geometric definition

5. Verify that $(y-1) = \frac{1}{4}x^2$ is the equation of the parabola in *figure 1* by plugging in the 3 points V $(0,1)$, C $(4,5)$ and E $(2,2)$. Show your work for each point!

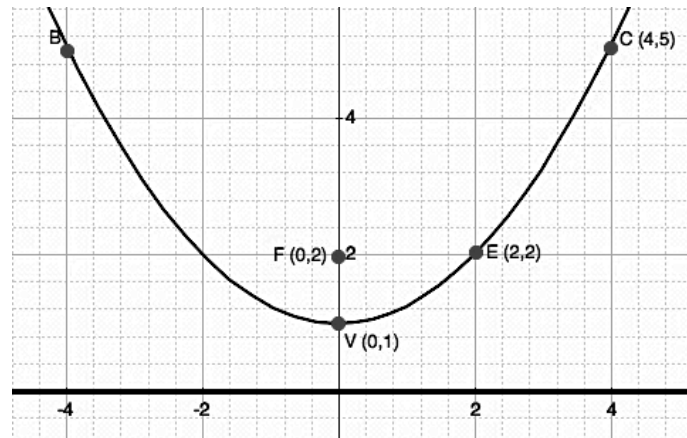

Figure 1

6. If you didn't know that $(0,1)$ was the vertex of the parabola, could you have found it by just looking at the equation? Explain.



7. Use the diagram in *figure 2* to derive the general equation of a parabola based on the **geometric definition** of a parabola. Remember that the definition states that $PF = PQ$.

figure 2

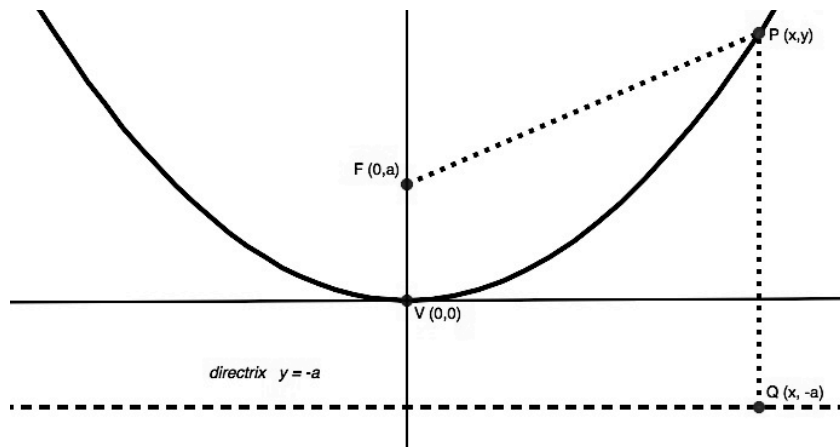

8. Recall the equation in #5, $(y-1) = \frac{1}{4}x^2$, what is the value of a ?

9. In general, what is the value of a in any parabola?

10. In *figure 3*, the point M is the same height as the focus and $\overline{FM} \cong \overline{MR}$. How do the coordinates of this point compare with the coordinates of the focus? Fill in the missing coordinates for M and R in the diagram.

figure 3

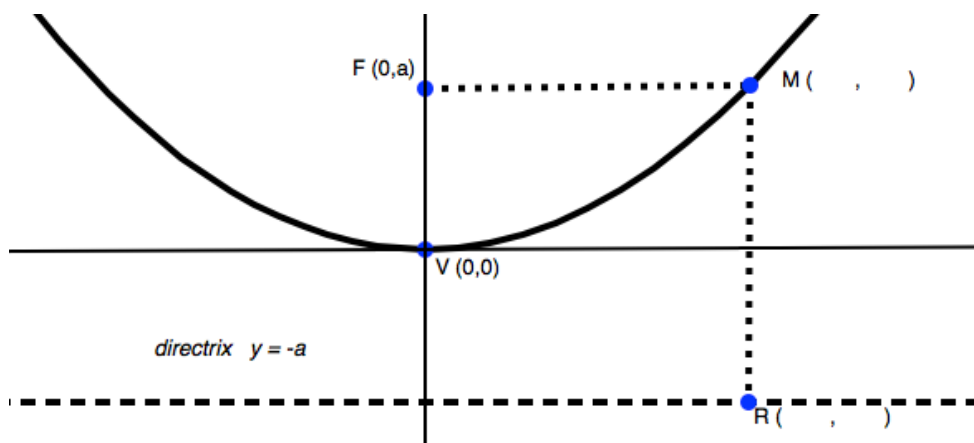

Sketch the graph by finding the vertex and the point M and M' (the reflection of M) as defined in the diagram above. Use the geometric definition of a parabola to find the equation of these parabolas.

11. Directrix $y = 9$, Focus A(-3, 7)

Vertex _____

Equation _____

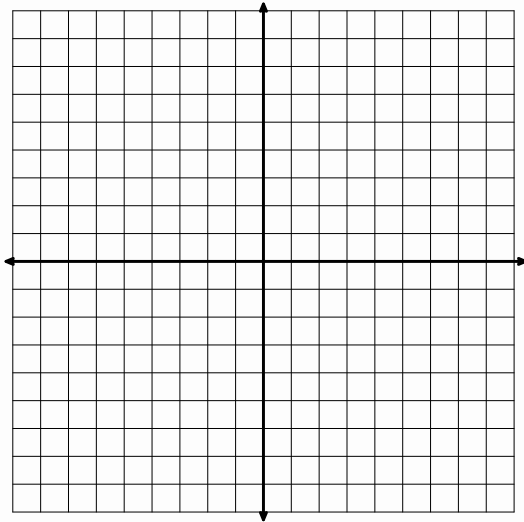

12. Directrix $y = -6$, Focus A(2, -2)

Vertex _____

Equation _____

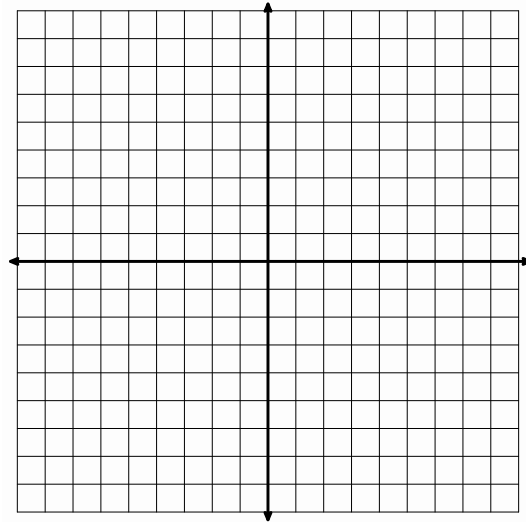

13. Directrix $y = 5$, Focus A(-4, -1)

Vertex _____

Equation _____

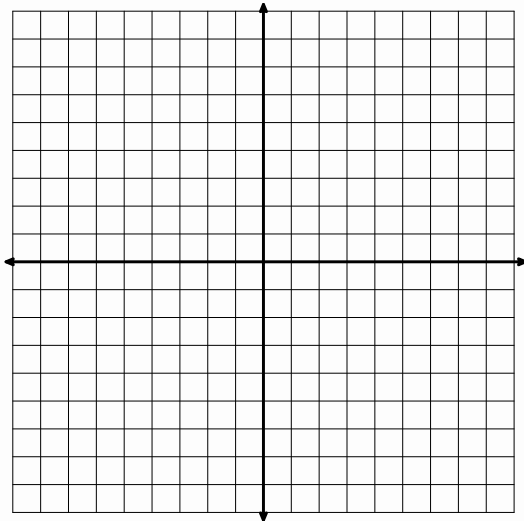

14. Directrix $y = -1$, Focus A(4, -3)

Vertex _____

Equation _____

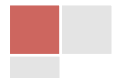
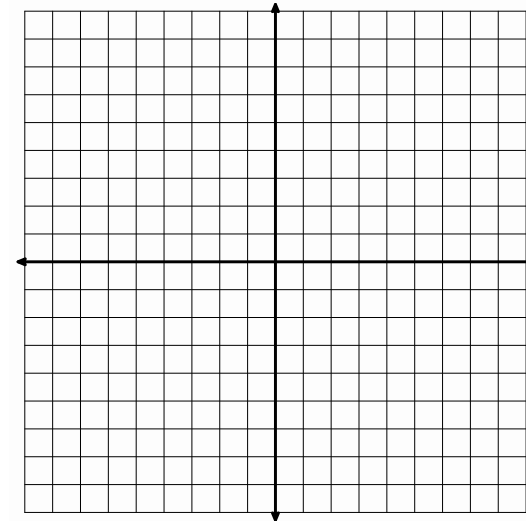

Go

Find the maximum or minimum value of the quadratic. Indicate which it is.

15. $y = x^2 + 6x - 5$

16. $y = 3x^2 - 12x + 8$

17. $y = -\frac{1}{2}x^2 + 10x + 13$

18. $y = -5x^2 + 20x - 11$

19. $y = \frac{7}{2}x^2 - 21x - 3$

20. $y = -\frac{3}{2}x^2 + 9x + 25$

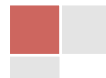

8.6 Turn It Around

A Solidify Understanding Task

Annika is thinking more about the geometric view of parabolas that she has been working on in math class. She thinks, “Now I see how all the parabolas that come from graphing quadratic functions could also come from a given focus and directrix. I notice that all the parabolas have opened up or down when the directrix is horizontal. I wonder what would happen if I rotated the focus and directrix 90 degrees so that the directrix is vertical. How would that look? What would the equation be? Hmmm....” So Annika starts trying to construct a parabola with a vertical directrix. Here’s the beginning of her drawing. Use a ruler to complete Annika’s drawing.



© 2013 www.flickr.com/photos/robwallace

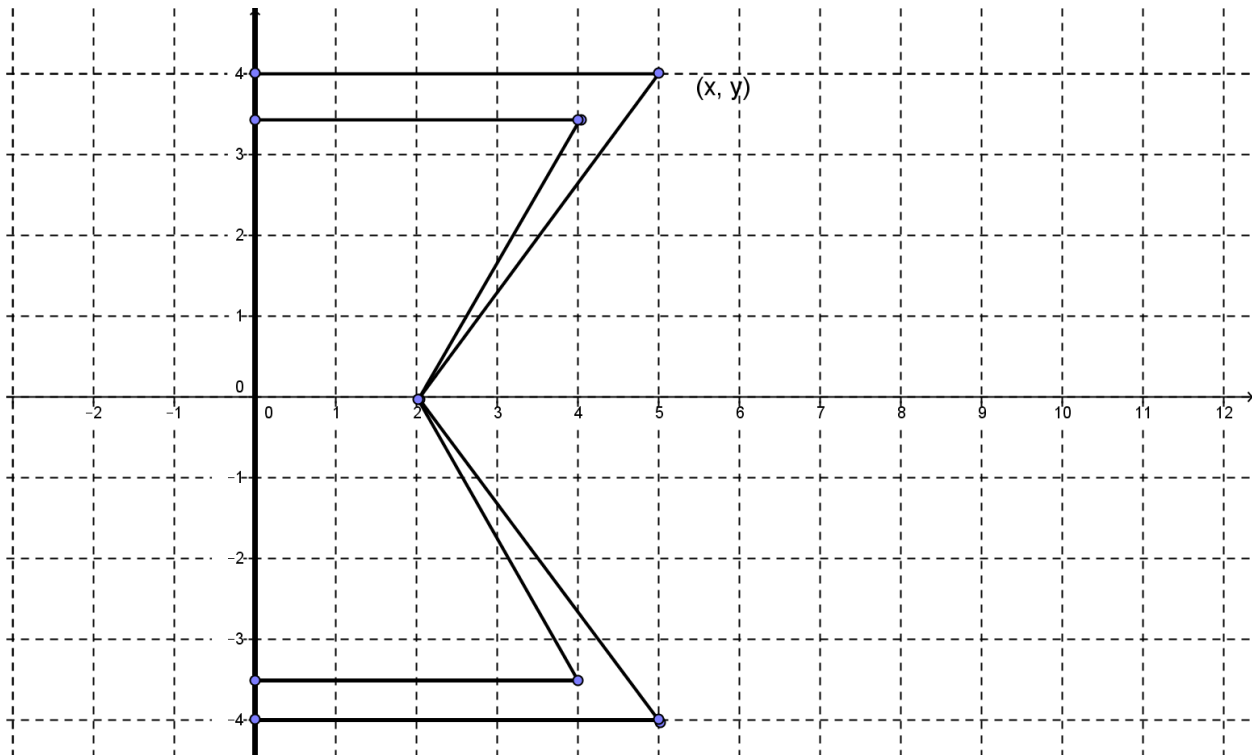

1. Use the definition of a parabola to write the equation of Annika’s parabola.



2. What similarities do you see to the equations of parabolas that open up or down? What differences do you see?
3. Try another one: Write the equation of the parabola with directrix $x = 4$ and focus $(0, 3)$.
4. One more for good measure: Write the equation of the parabola with directrix $x = -3$ and focus $(-2, -5)$.
5. How can you predict if a parabola will open left, right, up, or down?
6. How can you tell how wide or narrow a parabola is?
7. Annika has two big questions left. Write and explain your answers to these questions.
 - a. Are parabolas functions?
 - b. Are all parabolas similar?



Turn It Around – Teacher Notes

A Solidify Understanding Task

Special Note to Teachers: Rulers should be available for student use in this task.

Purpose: The purpose of this task is to generalize the work that students have done with parabolas that have a horizontal directrix (including those generated as quadratic functions), and extend the idea to parabolas with a vertical directrix. In the task, they graph and write equations for parabolas that have vertical directrices. They are asked to consider the idea that not all parabolas are functions, even though they have quadratic equations. The task ends with constructing an argument that all parabolas, like circles, are similar.

Core Standards Focus:

G.GPE Expressing Geometric Properties with Equations

Translate between the geometric description and the equation for a conic section

G.GPE.2. Derive the equation of a parabola given a focus and directrix.

Note: Connect the equations of circles and parabolas to prior work with quadratic equations. The directrix should be parallel to a coordinate axis.

Launch (Whole Class): Before handing out the task, ask students to think back to the lesson when they constructed a parabola by placing tacks on a board with a given focus and horizontal directrix. Ask students what shape would be constructed if they did the same thing with the strings and tacks, but the directrix was vertical and the focus was to the right of the directrix. After a brief discussion, distribute the task and have students complete the diagram and write the equation of the parabola. Ask a student to demonstrate how they wrote the equation using the distance formulas, just like they did previously with other parabolas. After the demonstration, students can work together to discuss the remaining questions in the task.

Explore (Small Group): Monitor student work as they write the equations to see that they are considering which expressions to expand and simplify. Since they have previously expanded the y^2 expression, they may not recognize that it will be more convenient in this case to expand the $(x - b)^2$ term.

Listen to student discussion of #7 to find productive comments for the class discussion. Students should be talking about the idea that a function has exactly one output for each input, unlike these parabolas. Some may also talk about the vertical line test. Encourage them to explain the basis for the vertical line test, rather than just to cite it as a rule.



The question about whether all parabolas are similar may be more controversial because they don't seem to look similar in the way that other shapes do. Listen to students that are reasoning using the ideas of translation and dilation, particularly noting how they can justify this using a geometric perspective with the definition or arguing from the equation.

Discuss (Whole Class): Begin the discussion with question #5. Press students to explain how to tell which direction the parabola opens given an equation or focus and directrix. Create a chart that solidifies the conclusions for students.

Move the discussion to question #7a. Ask students to describe why some parabolas are not functions. Be sure that the discussion relies on the idea of a function having exactly one output for each input, rather than simply the vertical line test or the idea that it's not a function if the equation contains a y^2 . In either case, press students to relate their idea to the definition of function.

Close the discussion with students' ideas about question #7b. Allow the arguments to be informal, but focused on how they know that any parabola can be obtained from any other by the process of dilation and translation. A good visual argument of this idea can be viewed at:

<http://frink.machighway.com/~dynamicm/similarparabola.html>.

Aligned Ready, Set, Go: *Circles and Other Conics 8.6*



Name: _____

Circles and Other Conics | 8.6

Ready, Set, Go!



© 2013 www.flickr.com/photos/robwallace

Ready

Topic: Are you ready for a test on module 8? Review of circles

Use the given information to write the equation of the circle in standard form.

- Center: $(-5, -8)$, Radius: 11
- Endpoints of the diameter: $(6, 0)$ and $(2, -4)$
- Center $(-5, 4)$: Point on the circle $(-9, 1)$
- Equation of the circle in the diagram.

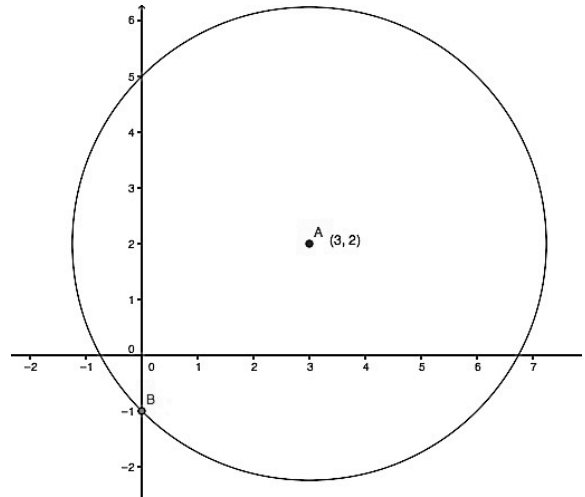

Set

Topic: Writing equations of horizontal parabolas

Use the focus F , point P , a point on the parabola, and the equation of the directrix to sketch the parabola (label your points) and write the equation. Put your equation in the form $(x - h) = \frac{1}{4a}(y - k)^2$ where "a" is the distance from the focus to the vertex.

5. $F(1,0)$, $P(1,4)$ $x = -3$

6. $F(3,1)$, $P(2,-5)$ $x = 9$

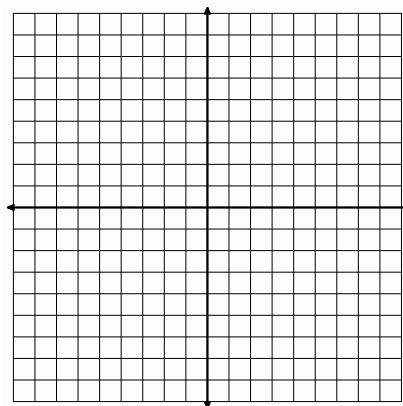
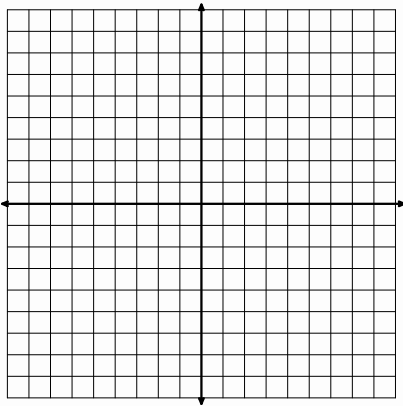

© 2013 MATHEMATICS VISION PROJECT | MVP

In partnership with the Utah State Office of Education

Licensed under the Creative Commons Attribution-NonCommercial-ShareAlike 3.0 Unported license



7. $F(7,-5)$, $P(4,-1)$ $x = 9$

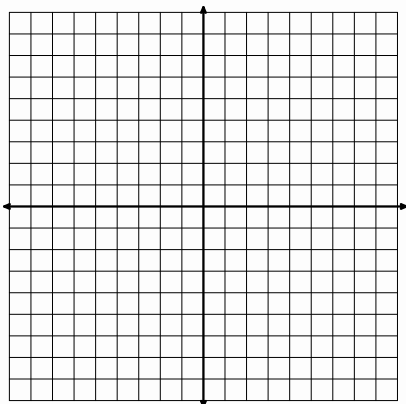

8. $F(-1,2)$, $P(6,-9)$ $x = -7$

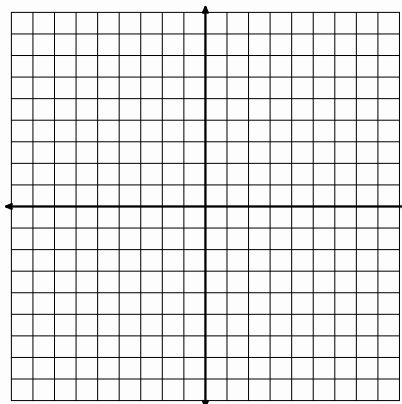
**Go**

Topic: Identifying key features of a quadratic written in vertex form

State (a) the coordinates of the vertex, (b) the equation of the axis of symmetry, (c) the domain, and (d) the range for each of the following functions.

9. $f(x) = (x-3)^2 + 5$

10. $f(x) = (x+1)^2 - 2$

11. $f(x) = -(x-3)^2 - 7$

12. $f(x) = -3\left(x - \frac{3}{4}\right)^2 + \frac{4}{5}$

13. $f(x) = \frac{1}{2}(x-4)^2 + 1$

14. $f(x) = \frac{1}{4}(x+2)^2 - 4$

15. Compare the vertex form of a quadratic to the geometric equation of a parabola. Describe how they are similar and how they are different.



8.7H Operating on a Shoestring

A Solidify Understanding Task

You will need 3 pieces of paper, a piece of cardboard that is at least 8" x 8", 2 tacks, 36 inches of string, and a pencil

1. Cut three pieces of string: a 10 inch piece, a 12 inch piece, and a 14 inch piece. Tie the ends of each piece of string together, making 3 loops.

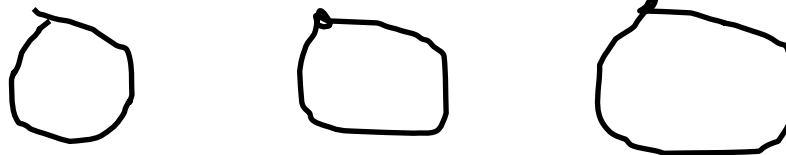

2. Place a piece of paper on top of the cardboard.
3. Place the two tacks 4 inches apart, wrap the string around the tacks and then press the tacks down.
4. Pull the string tight between the two tacks and hold them down between your finger and thumb. Pull the string tight so that it forms a triangle, as shown below. What is the length of the part of the string that is not on the segment between the two tacks, the sum of the lengths of the segments marked d_1 and d_2 in the diagram?
5. With your pencil in the loop and the string pulled tight, move your pencil around the path that keeps the string tight.

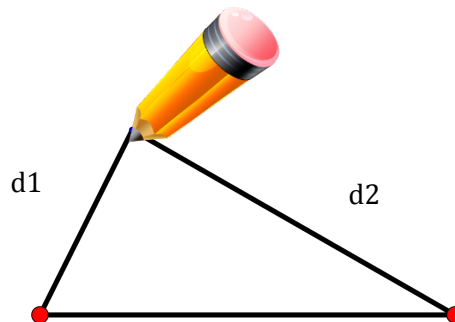

6. What shape is formed? What geometric features of the figure do you notice?
7. Repeat the process again using the other strings. What is the effect of the length of the string?



www.flickr.com/photos/fdecomite



8. What is the effect of changing the distance between the two tacks? (You may have to experiment to find this answer.)

The geometric figure that you have created is called an ellipse. The two tacks each represent a focus point for the ellipse. (The plural of the word “focus” is “foci”, but “focuses” is also correct.)

To focus our observations about the ellipse, we’re going to slow the process down and look at points on the ellipse in particular positions. To help make the labeling easier, we will place the ellipse on the coordinate plane.

9. The distances from the point on the ellipse to each of the two foci is labeled d_1 and d_2 .

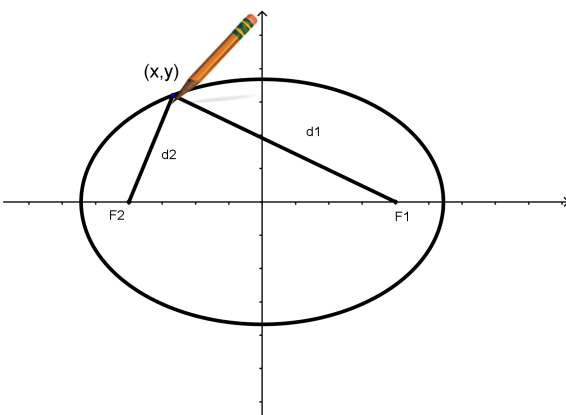

Figure 1

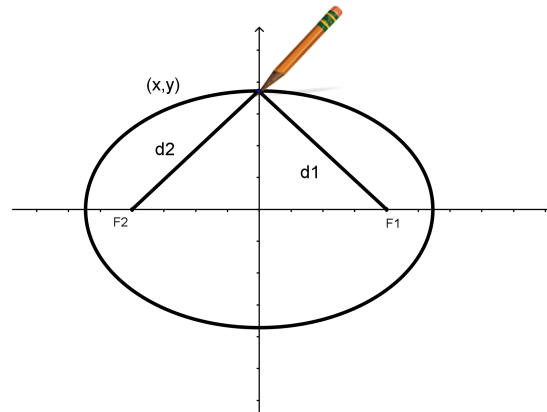

Figure 2

How does $d_1 + d_2$ in Figure 1 compare to $d_1 + d_2$ in Figure 2? (Figure 1 and Figure 2 are the same ellipse.)

10. How does $d_1 + d_2$ compare to the length of the ellipse, measured from one end to the other along the x-axis? Explain your answer with a diagram.



You have just constructed an ellipse based upon the definition: An ellipse is the set of all points (x, y) in a plane which have the same total distance from two fixed points called the foci. Like circles and parabolas, ellipses also have equations. The basic equation of the ellipse is derived in a way that is similar to the equation of a parabola or a circle. Since it's usually easier to start with a specific case and then generalize, we'll start with this ellipse:

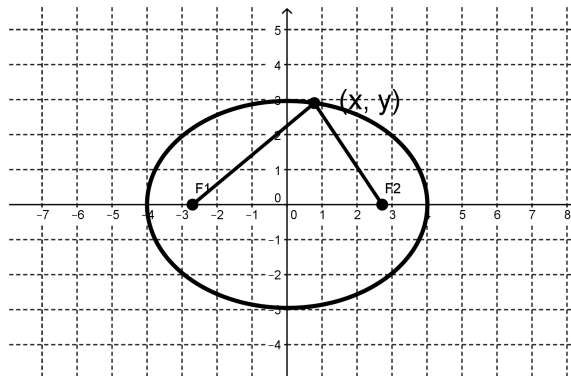

11. Now, use the conclusions that you drew earlier to help you to write an equation. (We'll help with a few prompts.)
- What is the sum of the distances from a point (x, y) on this ellipse to F_1 and F_2 ?
 - Write an expression for the distance between the point (x, y) on the ellipse and $F_1(-3,0)$.
 - Write an expression for the distance between (x,y) on the ellipse and $F_2 (3,0)$.
 - Use your answers to a, b, and c to write an equation.

12. The equation of this ellipse in standard form is:

$$\frac{x^2}{16} + \frac{y^2}{9} = 1$$



It might be much trickier than you would imagine to re-arrange your equation to check it, so we'll try a different strategy. This equation would say that the ellipse contains the points (4,0) and (0,-3). Do both of these points make your equation true? Show how you checked them here.

13. Using the standard form of the equation is actually pretty easy, but you have to notice a few more relationships. Here's another picture with some different parts labeled.

a = horizontal distance from the center to the ellipse

b = vertical distance from the center to the ellipse

c = distance from the center to a focus

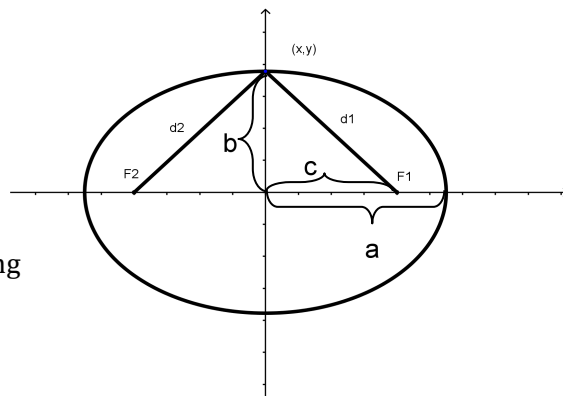

Based on the diagram, describe in words the following expressions:

2a

2b

2c

14. What is the mathematical relationship between a, b, and c?

15. Now you can use the standard form of the equation of an ellipse centered at (0,0) which is:

$$\frac{x^2}{a^2} + \frac{y^2}{b^2} = 1$$



Write the equation of each of the ellipses pictured below:

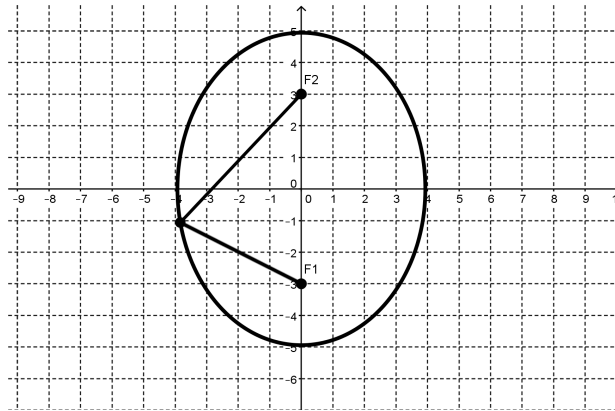
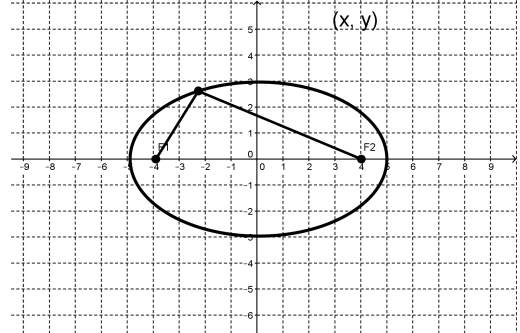
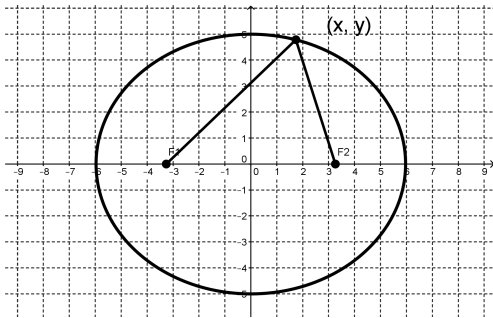

16. Based on your experience with shifting circles and parabolas away from the origin, write an equation for of this ellipse. Test your equation with some points on the ellipse that you can identify.

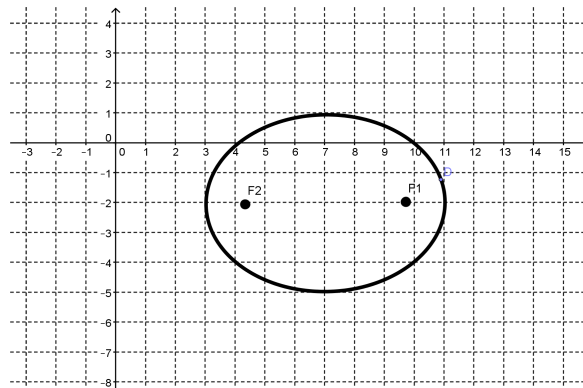

8.7H Operating on a Shoestring – Teacher Notes

A Solidify Understanding Task

Note: Having a dynamic sketch of an ellipse available for the class discussion would be very helpful. One possibility is a free applet available at: <http://www.cut-the-knot.org/Curriculum/Geometry/EllipseFocal.shtml>.

Purpose:

The purpose of this task is to develop the definition of a parabola as the set of all points equidistant from a given point (the focus) and a line (the directrix). Only those parabolas with horizontal directrices are considered in this task. Students develop an equation for a parabola based on the definition, using the distance formula. Students are also asked to consider the relationship between the focus and directrix and how the parabola changes as they are moved in relation to each other.

Core Standards Focus:

G.GPE Expressing Geometric Properties with Equations

Translate between the geometric description and the equation for a conic section

G.GPE.2. Derive the equation of a parabola given a focus and directrix.

Note: Connect the equations of circles and parabolas to prior work with quadratic equations. The directrix should be parallel to a coordinate axis.

Vocabulary: focus, directrix

Launch (Whole Class):

Be prepared for the class activity by having scissors, markers, rulers, and string for students to use. Have a large cork board with focus and directrix set up for students to use, as pictured in the task.

Lead the class in following the directions for cutting and marking the strings and then posting them on the board. Before anyone posts a string, ask students what shape they think will be made and why. Watch as students post their strings to be sure that they are perpendicular to the directrix and pulled tight both directions so that they look like the illustration.

After students have identified that the figure formed is a parabola, have them work individually on completing the diagram in #8. When completed, ask how they find the vertex point on a parabola? Be sure that the discussion includes the fact that the vertex will be the point on the line of symmetry that is the midpoint between the focus and the directrix. How is the vertex like other

© 2013 Mathematics Vision Project | MVP

In partnership with the Utah State Office of Education

Licensed under the Creative Commons Attribution-NonCommercial-ShareAlike 3.0 Unported license



points on the parabola? (It is equidistant from the focus and the directrix.) How is it different? (It's the only point of the parabola on the line of symmetry.) Direct the discussion to the line of symmetry. Where is it on the parabola they just made? How could it be found on any parabola, given the focus and directrix?

After their work on #8, explain the geometric definition of a parabola given in #9. Then have students work together to use the definition to write the equation of the parabola.

Explore (Small Group):

Monitor students as they work to be sure that they are using the point marked (x, y) to represent any point on the parabola, rather than naming it $(4,5)$. If they have written the equation using $(4,5)$ then ask them how they would change their initial equation to call the point (x, y) instead. After they have written their equation they may want to test it with the point $(4, 5)$ since they know it is on the parabola. If students need help getting started, help them to focus on the distance between the (x, y) and the focus $(0,2)$ and (x, y) and the directrix, $y = 0$. Ask how they could represent those distances algebraically.

Be sure that students have time to share their ideas about problems 10 -12 so that the class discussion of the relationship of the focus and the directrix is robust.

Discuss (Whole Class):

When students have finished their work on the equation, ask a group to present and explain their work. A possible version is below:

Distance from (x, y) to focus $(0, 2)$ = distance from (x, y) to x-axis

$$\begin{aligned} \sqrt{(x - 0)^2 + (y - 2)^2} &= y \\ (x - 0)^2 + (y - 2)^2 &= y^2 && \text{Squaring both sides} \\ x^2 + y^2 - 4y + 4 &= y^2 && \text{Simplifying} \\ x^2 - 4y + 4 &= 0 && \text{Simplifying} \\ x^2 + 4 &= 4y && \text{Solving for y} \\ \frac{x^2}{4} + 1 &= y && \text{Solving for y} \end{aligned}$$

Ask students how this equation matches what they already know about the parabola they have drawn. Where is the vertex in the equation? How could they use the equation to predict how wide or narrow the parabola will be?



Turn the discussion to questions 10 -12. Ask various students to explain their answers. Use the parabola applet to test their conjectures about the effect of moving the focus in relation to the directrix.

Aligned Ready, Set, Go: *Circles and Other Conics 8.4*



Name: _____

Circles and Other Conics | 8.7H

Ready, Set, Go!

www.flickr.com/photos/fdecomite

Ready

Topic: Solving radical equations.

Solve for x. Beware of *extraneous solutions*.

1. $\sqrt{2x - 5} = 3$

2. $\sqrt{10x + 9} = 13$

3. $\sqrt{2x} = x - 4$

4. $3\sqrt{2x + 2} = 2\sqrt{5x - 1}$

5. $x - 3 = \sqrt{3x + 1}$

6. $4 - \sqrt{10 - 3x} = x$

Set Topic: Graphing Ellipses

Find the x- and y- intercepts of the ellipse whose equation is given. Then draw the graph.

7. $\frac{x^2}{36} + \frac{y^2}{16} = 1$

8. $\frac{x^2}{9} + \frac{y^2}{64} = 1$

9. $\frac{x^2}{25} + \frac{y^2}{4} = 1$

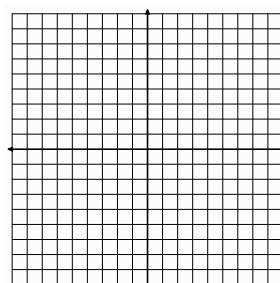
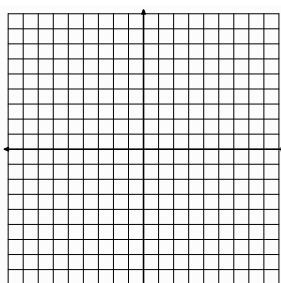
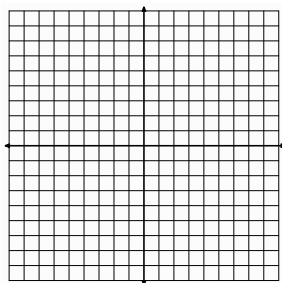

10. $x^2 + 4y^2 = 64$

11. $9x^2 + y^2 = 36$

12. $x^2 + 3y^2 = 75$

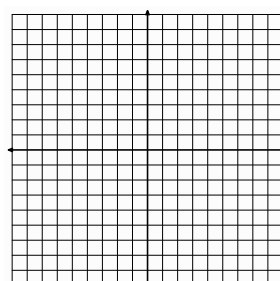
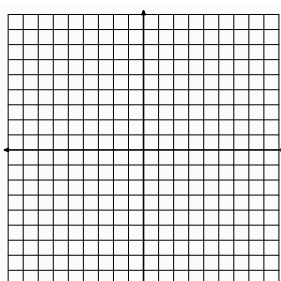
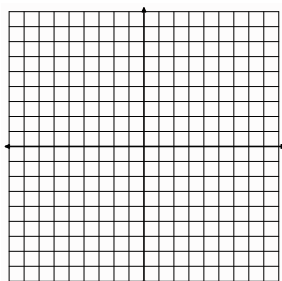

Write an equation, in standard form, for each ellipse, given its center C and its x - and y - intercepts.

12. $C(-2,3)$, $a = \pm 4$, $b = \pm 2$

13. $C(5,2)$, $a = \pm 3$, $b = \pm 5$

14. $C(-4,-7)$, $a = \pm 10$, $b = \pm 8$

15. $C(6,-5)$, $a = \pm 7$, $b = \pm \sqrt{11}$

Write the equation of each ellipse in standard form. Identify the center. Then graph the ellipse.

16. $4x^2 + y^2 - 32x - 4y + 52 = 0$

17. $16x^2 + 9y^2 - 96x + 72y + 144 = 0$

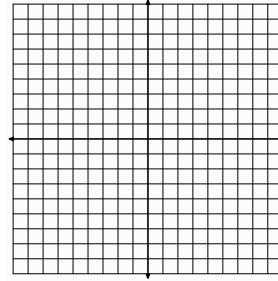
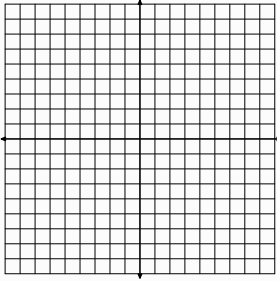

Go

Topic: Point-Slope form of a line.

The rectangle in figure B is a translation of the rectangle in figure A. Write the equations of the 2 diagonals of rectangle $ABCD$ in point-slope form. Then write the equations of the 2 diagonals of $A'B'C'D'$.

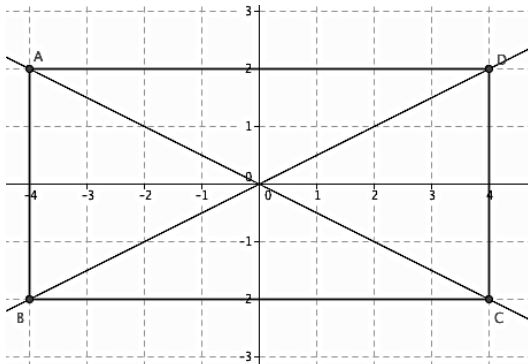
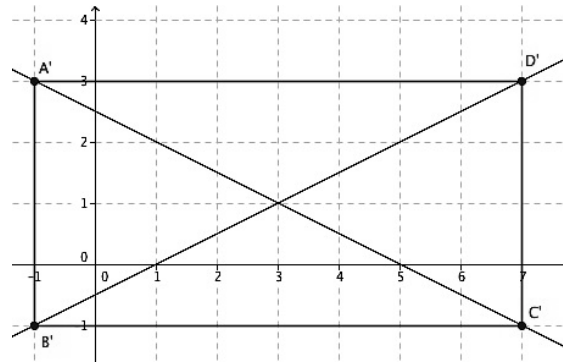
18. *figure A**figure B*

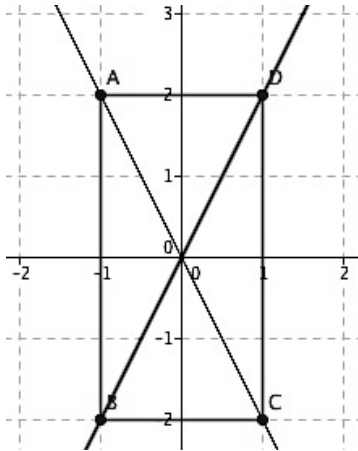
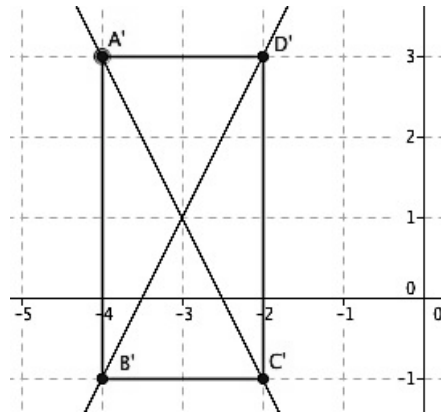
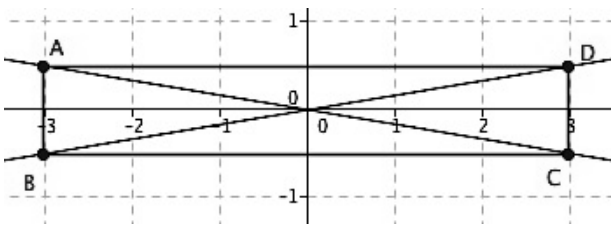
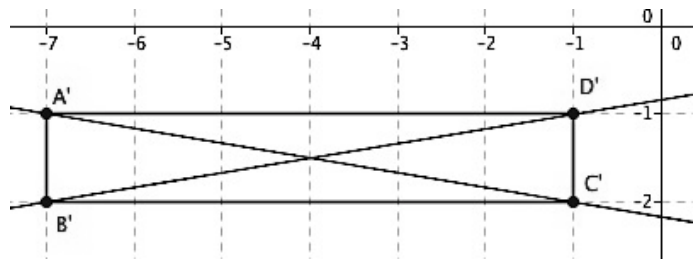
19. *figure A**figure B*20. *figure A**figure B*

21. The equations of the diagonals of rectangle JKLM are $y_1 = 5/8x$ and $y_2 = -5/8x$. Rectangle JKLM is then translated so that its diagonals intersect at the point $(12, -9)$. Write the equation of the diagonals of the translated rectangle.



8.8H What Happens If ...?

A Solidify Understanding Task

After spending some time working with circles and ellipses, Maya notices that the equations are a lot alike. For example, here's an equation of an ellipse and a circle:

$$\frac{x^2}{16} + \frac{y^2}{9} = 1 \quad x^2 + y^2 = 16$$



www.flickr.com/photos/amygroark/4091608467

1. What are some of the similarities between the circle and the ellipse given in the equations above? What are some of the differences?
2. Maya wonders what would happen if she took the equation of the circle and rearranged it so the right hand side was 1, like the standard form of an ellipse. What does the equation of the circle become?
3. After seeing this equation Maya wonders if a circle is really an ellipse, or if an ellipse is really a circle. How would you answer this question?
4. Maya looks at the equation of the ellipse and wonders what would happen if the “+” in the equation was replaced with a “-”, making the equation:

$$\frac{x^2}{16} - \frac{y^2}{9} = 1$$

Without making any further calculations or graphing any points, predict whether or not the graph of this equation will be an ellipse? Using what you know about ellipses, explain your answer.



5. Graph the equation to determine whether or not your prediction was correct. Be sure to use enough points to get a full picture of the figure.

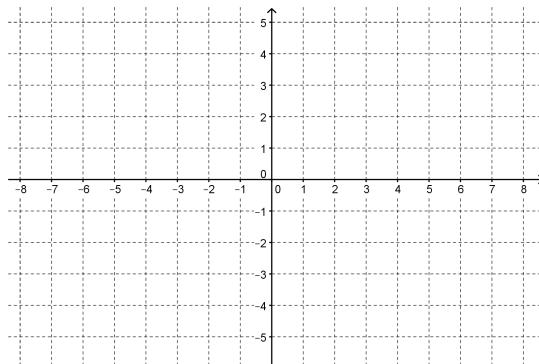

6. What are some of the features of the figure that you have graphed?

7. Maya's teacher tells her that the name of the figure represented in each of the two equations is a hyperbola. Maya wonders what would happen if the x^2 term in the equation was switched with the y^2 term, making the equation:

$$\frac{y^2}{9} - \frac{x^2}{16} = 1$$

Graph this equation and compare it to the hyperbola that you graphed previously.

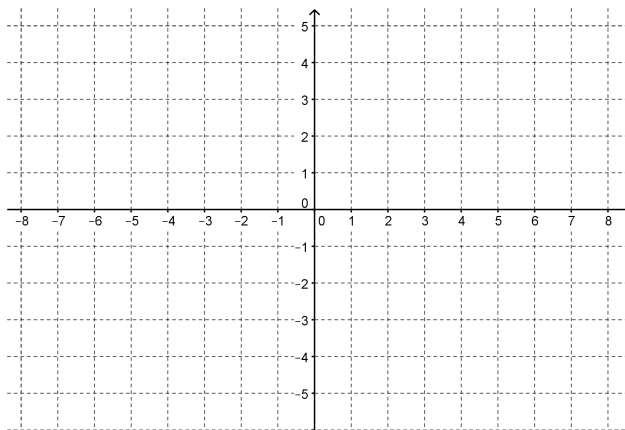

8. What similarities and differences do you see between this hyperbola and the one that you graphed in #5?

One strategy that makes it easier to graph the hyperbola from an equation is to notice that the square root of the numbers under the x^2 and y^2 terms can be used to make a rectangle and then to draw dotted lines through the diagonals that form the boundaries of the hyperbola. Using this strategy to graph the equation: $\frac{y^2}{9} - \frac{x^2}{16} = 1$, you would start by taking the square root of $9 = 3$ and going up and down 3 units from the origin. Then you take the square root of $16 = 4$ and go left and right 4 units from the origin. Make a rectangle with these points on the sides and draw the diagonals. You will get this:

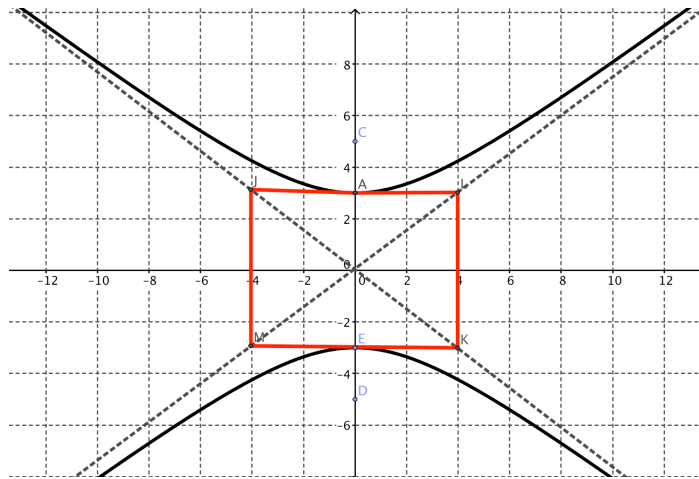

9. So, Maya, the bold math adventurer, decides to try it with a new equation of a hyperbola. The standard form of the equation of an hyperbola centered at $(0,0)$ is:

$$\frac{x^2}{a^2} - \frac{y^2}{b^2} = 1 \text{ (opens left and right)}$$

$$\frac{y^2}{a^2} - \frac{x^2}{b^2} = 1 \text{ (opens up and down)}$$



Maya goes to work graphing the equation:

$$\frac{x^2}{36} - \frac{y^2}{25} = 1$$

Try it yourself and see what you can come up with.

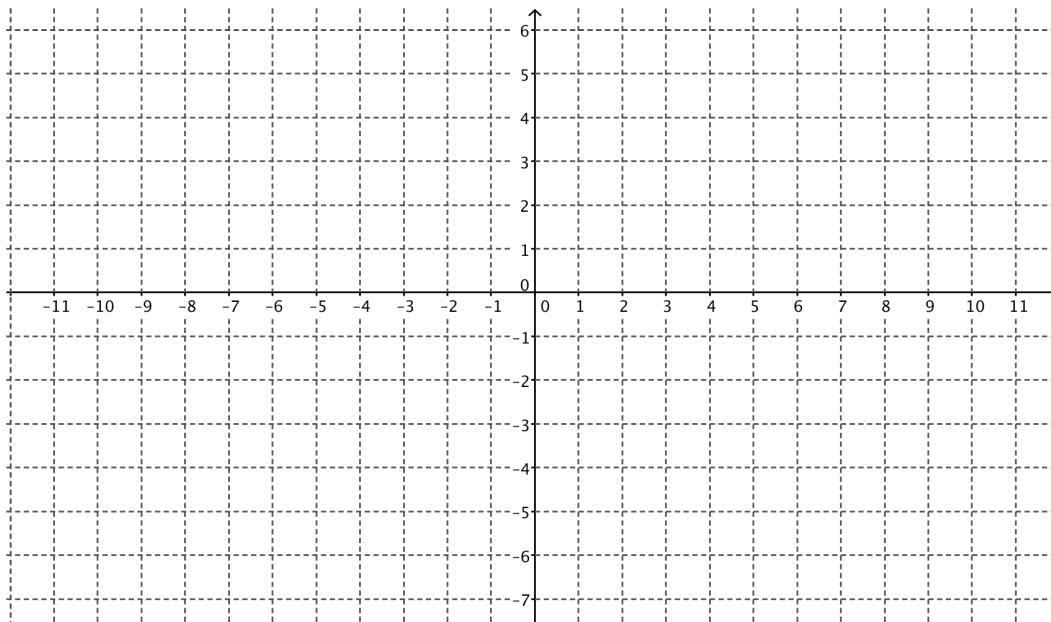

10. Maya wonders what happens if the equation becomes:

$$\frac{(x-1)^2}{36} - \frac{(y+2)^2}{25} = 1$$

What is your prediction? Why?



11. Write the equation of the hyperbola shown below:

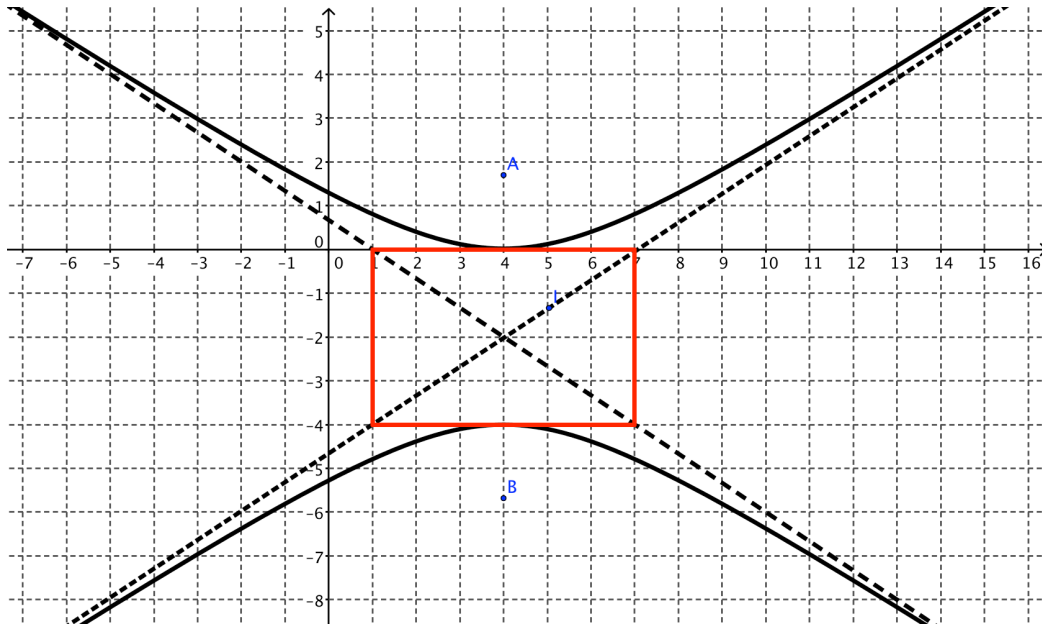

11. What similarities and differences do you see between a hyperbola and an ellipse?



8.8H What Happens If . . .? – Teacher Notes

A Solidify Understanding Task

Purpose:

The purpose of this task is to develop the definition of a hyperbola as the set of all points in a plane such that the difference between the distances from the point to each of the two foci is constant. The task is designed so that students draw upon their previous work with constructing ellipses and working with their equations to extend to equations of hyperbolas. The task begins with circles and ellipses and then asks them to consider what type of graph would be created if the equation was changed from addition to subtraction. The class discussion includes identifying the foci and the introducing the definition of the hyperbola.

Core Standards Focus:

G.GPE Expressing Geometric Properties with Equations

Translate between the geometric description and the equation for a conic section

G.GPE.3(+) Derive the equations of ellipses and hyperbolas given the foci, using the fact that the sum or difference of distances from the foci is constant.

Vocabulary: hyperbola, asymptote

Launch (Whole Class):

The task begins by asking students to consider their previous work with ellipses and circles, making comparisons between the two figures. Ask students to work questions 1-3 and then have a short discussion of their conclusions about the relationship between circles and ellipses. Remind students of the definition of the ellipse and ask students where the foci must be for a circle.

Ask students to read questions #4 and to make predictions about the features of the graph based on the equation. Will the graph be symmetrical about the x-axis? Will the graph be symmetrical about the y-axis? Will the graph be a function? After making predictions have students work problems 4-6.

Explore (Small Group):

Monitor students as they work. You may need to support students in using the equation to plot points. The task will be very tedious if they are not using calculators to do the arithmetic necessary. You may choose to discourage the use of the graphing function of the calculator just so students think about how the symmetries occur using the equation. Some students will probably solve the

© 2013 Mathematics Vision Project | MVP

In partnership with the Utah State Office of Education

Licensed under the Creative Commons Attribution-NonCommercial-ShareAlike 3.0 Unported license



equation for y (or x). Watch to see if they consider both the principal and the negative root of the expression. If they don't use the negative root, they will miss half of the graph, which would be an interesting discussion point when compared to students that used enough points to get the entire graph.

Discuss (Whole Class):

Ask a student to present their graph. You may wish to start with a group that only found part of the graph because they didn't do both the positive and negative root. When other students show the complete graph, discuss why the strategy of the solving for y may not yield the whole graph if the $\pm\sqrt{\quad}$ isn't considered.

Explain to students that the figure that they have graphed is a hyperbola. Use technology to project the graph for the class and ask them to describe the features. Tell students that hyperbolas are also defined based upon the distances from a point to each of two foci. An ellipse is the set of all points such that the sum of the distances to the foci is constant. The hyperbola is the set of all points such that the difference of the distances to the foci is constant. The foci of this hyperbola are at $(5,0)$ and $(-5,0)$ and the segments showing the distances between the foci and a point of the hyperbola are shown below.

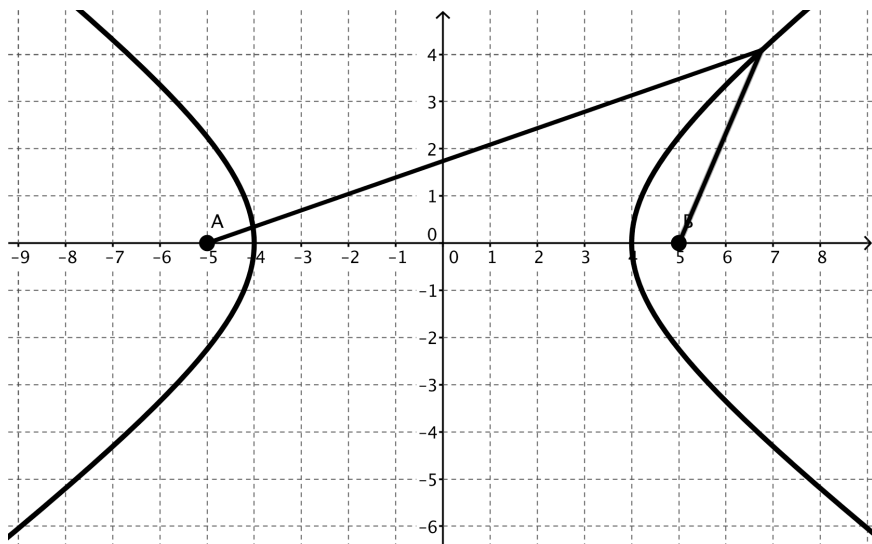

At this point, ask students to complete the task. Monitor their work and then call them back to discuss the remainder of the task. During the discussion of #9, help students clarify the use of a and b in the equation and using them to draw the rectangle that aids in graphing the hyperbola. Then, tell them that they can also be used to find the foci, with the relationship $a^2 + b^2 = c^2$, given that c is the distance from the center of the hyperbola to a focus. You may also wish to introduce the term, "asymptote" to describe the lines that are used to define the "borders" of the hyperbola.

Aligned Ready, Set, Go: *Circles and Other Conics 8.8H*

© 2013 Mathematics Vision Project | MVP

In partnership with the Utah State Office of Education

Licensed under the Creative Commons Attribution-NonCommercial-ShareAlike 3.0 Unported license



Name:

Circles and Other Conics | 8.8H

Ready, Set, Go!**Ready**

Topic: Identifying conic sections by their equations.

Identify each conic section by the given equation.

1. $\frac{x^2}{25} + \frac{y^2}{12} = 1$

2. $\frac{x^2}{4} - \frac{y^2}{16} = 1$

3. $\frac{x^2}{49} + \frac{y^2}{49} = 1$

4. $x^2 = 16 + y$

5. $9x^2 = 36 + 4y^2$

6. $9x^2 = 36 - 9y^2$

7. $y = \frac{x+4}{y}$

8. $7x^2 - 8y^2 = 35$

9. $5x^2 - 2y^2 - 15 = -6y^2 + 5$

Set Topic: Graphing hyperbolas

Write the equation of the asymptotes. Then sketch the graph of the given equation.

10. $\frac{x^2}{16} - \frac{y^2}{25} = 1$

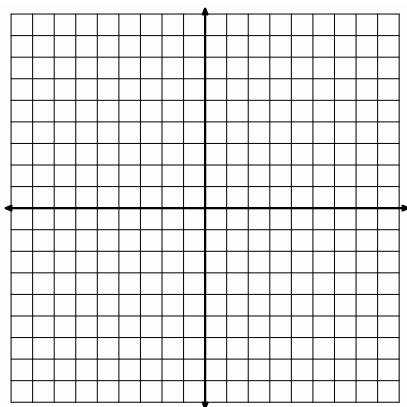

11. $\frac{y^2}{16} - \frac{x^2}{25} = 1$

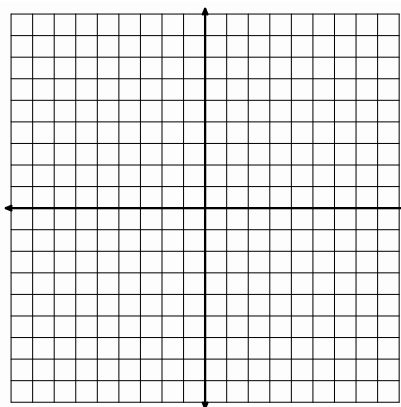
www.flickr.com/photos/amygroark/4091608467

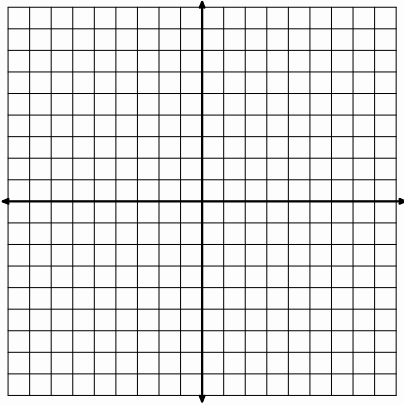

12. $\frac{y^2}{9} - \frac{x^2}{4} = 1$

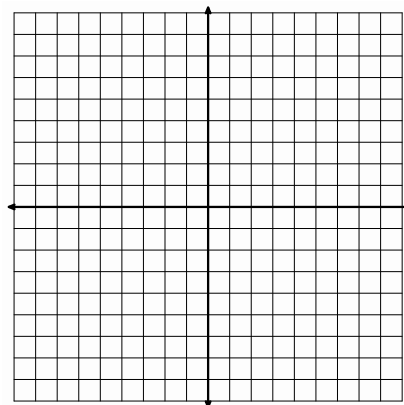

13. $\frac{x^2}{49} - \frac{y^2}{36} = 1$

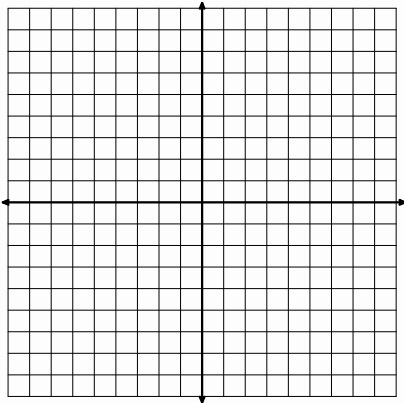

14. $4x^2 - 16y^2 = 64$



15. $12x^2 - 3y^2 = 48$

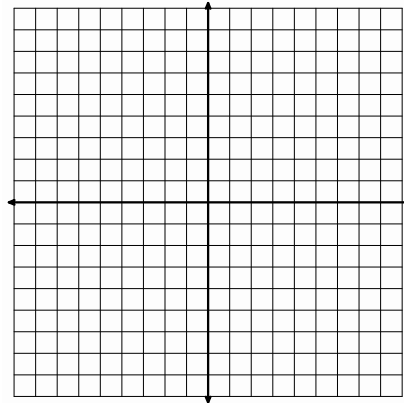

16. $\frac{(x-3)^2}{16} - \frac{(y+2)^2}{9} = 1$

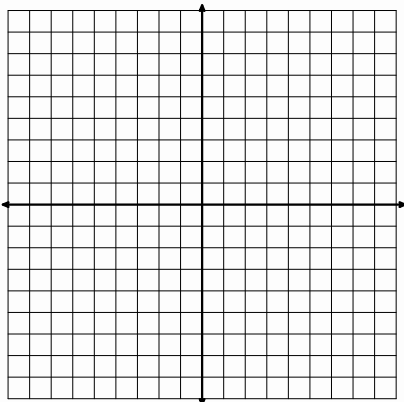

17. $\frac{(y-5)^2}{4} - \frac{(x-3)^2}{9} = 1$

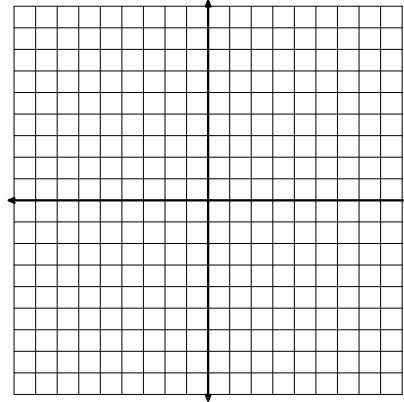

Go

Topic: Writing the equations of conic sections in standard form

Write the equation in standard form by completing the square. Then identify the conic section.

If the conic is:

- a parabola, identify the vertex and the write the equation of the directrix.
- a circle, identify the center and the radius.
- an ellipse, identify the center and the lengths of the minor axis and major axis.
- a hyperbola, write the equations of the asymptotes.

18. $x^2 - 4x + y^2 + 6y = 1$

19. $16x^2 - 9y^2 - 72y - 288 = 0$

20. $2y^2 - 32x + 20y + 50 = 0$

21. $2x^2 + 3y^2 + 6x - 9y - 15 = 0$

